

# Integration of big data analysis and engineering advanced analytics to intelligently manage and control completion and artificial lift for selected well in Croatia

---

Miličević, Monika

Master's thesis / Diplomski rad

2019

*Degree Grantor / Ustanova koja je dodijelila akademski / stručni stupanj:* **University of Zagreb, Faculty of Mining, Geology and Petroleum Engineering / Sveučilište u Zagrebu, Rudarsko-geološko-naftni fakultet**

*Permanent link / Trajna poveznica:* <https://um.nsk.hr/um:nbn:hr:169:056127>

*Rights / Prava:* [In copyright](#)/[Zaštićeno autorskim pravom.](#)

*Download date / Datum preuzimanja:* **2024-07-11**



*Repository / Repozitorij:*

[Faculty of Mining, Geology and Petroleum Engineering Repository, University of Zagreb](#)



UNIVERSITY OF ZAGREB  
FACULTY OF MINING, GEOLOGY AND PETROLEUM ENGINEERING  
Graduate study program in Petroleum Engineering

INTEGRATION OF BIG DATA ANALYSIS AND ENGINEERING ADVANCED  
ANALYTICS TO INTELLIGENTLY MANAGE AND CONTROL COMPLETION AND  
ARTIFICIAL LIFT FOR SELECTED WELL IN CROATIA

Monika Miličević

N258

Master's Thesis

Zagreb, 2019.

INTEGRACIJA „BIG DATA“ ANALIZE I INŽENJERSKOG NAČINA  
RAZMIŠLJANJA S CILJEM UPRAVLJANJA I KONTROLIRANJA INTELIGENTNOG  
OPREMANJA I UMJETNOG NAČINA PODIZANJA NAFTE I PLINA ZA  
ODABRANU BUŠOTINU S PODRUČJA HRVATSKE

Monika Miličević

Diplomski rad izrađen: Sveučilište u Zagrebu  
Rudarsko-geološko-naftni fakultet  
Zavod za naftno inženjerstvo  
Pierottijeva 6, 10 000 Zagreb

Sažetak

Inženjeri kontinuirano istražuju nove tehnologije kako bi razradili kompleksnija ležišta i povećali njihov ukupni iscrpak ležišta. Jedan od načina je i inteligentno opremanje koje pruža mogućnost daljinskog nadgledanja i kontrole cjelokupnog procesa pridobivanja ugljikovodika, te optimizaciju cijelog procesa. U takvom sustavu operator donosi odluke na temelju podataka koji dolaze u stvarnom vremenu sa senzora postavljenih u bušotinu. Nadalje, strojno učenje (engl. *machine learning*) postaje sve popularnije i u naftnoj industriji. Primjenjuje se u automatizaciji procesa kako bi se smanjilo vrijeme i greške prilikom donošenja odluka. Cilj ovoga rada je spojiti inteligentno opremanje sa neuronskom mrežom na stvarnom primjeru plinske bušotine. Uz to, cilj je vidjeti može li neuronska mreža predvidjeti optimalne veličine intervalnog kontrolnog ventila za različite slučajeve.

Ključne riječi: inteligentno opremanje, intervalni kontrolni ventil, neuronska mreža, problem klasifikacije, predikcija

Diplomski rad sadrži: 73 stranice, 48 slika, 5 tablica i 38 referenci

Diplomski rad pohranjen: Knjižnica Rudarsko-geološko-naftnog fakulteta, Pierottijeva 6, 10 000 Zagreb

Mentori: Dr.sc. Borivoje Pašić, docent RGNF-a  
Dr.sc. Mišo Soleša, redoviti profesor na Montauniversität Leoben

Ocjenjivači: Dr.sc. Borivoje Pašić, docent RGNF-a  
Dr.sc. Vladislav Brkić, docent RGNF-a  
Dr.sc. Sonja Koščak Kolin, docentica RGNF-a

Datum obrane: 20. rujan 2019., Rudarsko-geološko-naftni fakultet, Sveučilište u Zagrebu

INTEGRATION OF BIG DATA ANALYSIS AND ENGINEERING ADVANCED  
ANALYTICS TO INTELLIGENTLY MANAGE AND CONTROL COMPLETIONS  
AND ARTIFICIAL LIFT FOR SELECTED WELL IN CROATIA

Monika Miličević

Master's Thesis completed at: University of Zagreb  
Faculty of Mining, Geology and Petroleum Engineering  
Department of Petroleum Engineering  
Pierottijeva 6, 10 000 Zagreb

Abstract

In order to reach more complex reservoir and increase ultimate recovery, engineers are searching for new technologies. One of these is intelligent completion which provides system monitoring, fluid production or injection control, and optimization. Operator can make decisions about managing completion based on real-time data coming from the downhole sensors. In addition, machine learning is becoming more popular in the oil industry. It finds application in automatization of processes and reducing time and error in decision making process. The aim of the thesis is to couple intelligent completion with machine learning (neural network) on the real example-gas well. The goal is to see if neural network can predict optimal interval control valve sizes for specific scenarios.

Key words: intelligent completion, ICV, neural network, classification problem, prediction

Master's Thesis contains: 73 pages, 48 pictures, 5 tables and 38 references

Thesis deposited in: Library of Faculty of Mining, Geology and Petroleum Engineering,  
Pierottijeva 6, 10 000 Zagreb

Supervisors: Assistant professor Borivoje Pašić, PhD  
University professor Mišo Soleša, PhD

Reviewers: Assistant professor Borivoje Pašić, PhD  
Assistant professor Vladislav Brkić, PhD  
Assistant professor Sonja Koščak Kolin, PhD

Date of defense: 20<sup>th</sup> of September 2019, Faculty of Mining, Geology and Petroleum  
Engineering, University of Zagreb

## Contents

<b>LIST OF FIGURES</b> .....	I
<b>LIST OF TABLES</b> .....	III
<b>NOMENCLATURE</b> .....	IV
<b>1. INTRODUCTION</b> .....	1
<b>2. INTELLIGENT COMPLETION</b> .....	3
<b>2.1. Application of intelligent completion</b> .....	4
<b>2.2. Components of an intelligent well</b> .....	5
2.2.1. Packers .....	5
2.2.2. Surface and downhole gauges and sensors .....	5
2.2.2.1. <i>Downhole gauges</i> .....	6
2.2.2.2. <i>Surface gauges</i> .....	6
2.2.3. Control, communication and power cables .....	7
2.2.3.1. <i>Hydraulic control system</i> .....	7
2.2.3.2. <i>Electro-hydraulic control system</i> .....	8
2.2.3.3. <i>Electric control system</i> .....	9
2.2.4. Flow control devices (ICD and ICV) .....	10
2.2.4.1. <i>Inflow control device (ICD)</i> .....	11
2.2.4.2. <i>Inflow control valve (ICV)</i> .....	15
2.2.5. Surface control system .....	17
<b>2.3. An example of evolution from smart wells to a smart field in Brunei, Champion West offshore field</b> .....	18
<b>2.4. Value assessment of intelligent well technology</b> .....	20
2.4.1. Example of value assessment performed by company <i>Shell</i> .....	21
<b>2.5. Challenges of intelligent completion well monitoring and control</b> .....	23
<b>3. DATA MINING AND BIG DATA ANALYSIS</b> .....	24
<b>3.1. Data mining phases</b> .....	25
3.1.1. Research understanding phase .....	26
3.1.2. Data understanding phase.....	26
3.1.3. Data preparation phase .....	26
3.1.4. Modelling phase .....	27
3.1.5. Evaluation phase .....	27
3.1.6. Deployment phase .....	27
<b>4. NEURAL NETWORK</b> .....	28

<b>4.1. Architecture of neural network</b> .....	29
4.1.1. Weights.....	30
4.1.2. Propagation function .....	30
4.1.3. Bias function .....	31
4.1.4. Activation function.....	32
<b>4.2. Fundamental principles of learning and training the neural network</b> .....	33
4.2.1. Challenges in training a neural network model.....	34
<b>4.3. Types of neural network</b> .....	34
4.3.1. Feedforward network .....	35
4.3.2. Recurrent neural networks (RNN) .....	37
4.3.3. Lattice network.....	38
<b>5. ANALYSIS OF A GAS WELL IN CROATIA</b> .....	39
<b>5.1. Production characteristics of well X</b> .....	40
<b>5.2. Building a physical model in commercial software PIPESIM</b> .....	42
5.2.1. Original model.....	42
5.2.2. Customized PIPESIM model .....	49
5.2.2.1. <i>Choke model</i> .....	52
5.2.2.2. <i>Different cases simulated in PIPESIM</i> .....	54
<b>6. NEURAL NETWORK MODEL FOR WELL X</b> .....	57
<b>6.1. Workflow for the neural network model</b> .....	58
5.2.2. Neural network for well X .....	59
<b>6.2. Discussion of the results</b> .....	66
<b>7. CONCLUSION</b> .....	68
<b>8. REFERENCES</b> .....	69
<b>9. APPENDIX</b> .....	73

## LIST OF FIGURES

Figure 2-1. Downhole components of intelligent completion.....	5
Figure 2-2. Three-zone intelligent completion with hydraulic control system N+1 .....	8
Figure 2-3. Three-zone intelligent completion with the electro-hydraulic system.....	9
Figure 2-4. Heel-toe effect in a horizontal well. Beginning of water and gas coning.....	10
Figure 2-5. Heel-toe effect in a horizontal well. Advanced water and gas coning .....	11
Figure 2-6. Comparison of completion with and without ICD and water and gas front respectively.....	12
Figure 2-7. Autonomous inflow control device Equi Flow by Haliburton .....	12
Figure 2-8. ICD helical-channel type .....	13
Figure 2-9. ICD nozzle type .....	14
Figure 2-10. ICD orifice type .....	14
Figure 2-11. First type of ICV .....	16
Figure 2-12. Newly developed ICV .....	17
Figure 2-13. Scheme of a smart well and how surface and downhole gauges are connected to the surface monitoring system.....	18
Figure 2-14. Scheme of how Shell smart field improvements and benefits are generated .	22
Figure 3-1. Data mining phases according to CRISP-DM .....	26
Figure 4-1. Architecture of neural network .....	29
Figure 4-2. Scheme of the artificial neuron and its components.....	30
Figure 4-3. Appropriate input in the neural network; no bias added.....	31
Figure 4-4. Inappropriate input corrected by bias neuron .....	32
Figure 4-5. Perceptron- the simplest model of neural network .....	35
Figure 4-6. Single-layer feedforward network .....	36
Figure 4-7. Multi-layer feedforward network fully connected.....	36
Figure 4-8. Multi-layer feedforward network not fully connected.....	37
Figure 4-9. Recurrent network with no self-feedback loops .....	37
Figure 4-10. Lattice network .....	38
Figure 5-1. Open and closed intervals in well X .....	40
Figure 5-2. Production characteristics of Well X .....	41
Figure 5-3. Production characteristics of Well X and time intervals (red line) for which analysis was performed .....	41

Figure 5-4. PIPESIM workflow .....	43
Figure 5-5. Fluid characteristics for interval A1, A6 and A12, and BOFluid that represents fluid produced from other intervals .....	43
Figure 5-6. Well X completion scheme, simulated in PIPESIM.....	45
Figure 5-7. Surface equipment of Well X .....	46
Figure 5-8. Well test data .....	47
Figure 5-9. Correlations used for calculation of IPR and VLP .....	48
Figure 5-10. Data matching .....	48
Figure 5-11. IPR and VLP curves .....	49
Figure 5-12. Different choke size performance for interval A1 .....	51
Figure 5-13. Different choke size performance for interval A6.....	51
Figure 5-14. Different choke size performance for interval A12 .....	52
Figure 6-1. Different types of learning and models in machine learning according to Matlab.....	57
Figure 6-2. Network/Data Manager window for creating neural network (Matlab).....	58
Figure 6-3. The architecture of the neural network for well X.....	60
Figure 6-4. Cross-entropy and percentage of misclassification for training, validation and testing set .....	61
Figure 6-5. Confusion matrix .....	63
Figure 6-6. Receiver operating characteristic plot.....	64
Figure 6-7. Training, validation and test performance plot.....	65
Figure 6-8. Training state plot .....	65
Figure 6-9. Error histogram.....	66



## LIST OF TABLES

Table 2-1. ICD and ICV sizes for certain hole size.....	11
Table 5-1. Casing design for well X.....	44
Table 5-2. List of installed equipment for customized PIPESIM model.....	50
Table 6-1. Example of the input and target subset data .....	60
Table 8-1. Example of the data generated in PIPESIM after system analysis and how optimal choke size is selected for certain case .....	73

## NOMENCLATURE

A, B, C – coefficients determined empirical  
A<sub>bean</sub> - choke area (m<sup>2</sup>)  
AI – artificial intelligence  
AICD – autonomous inflow control device  
CE – cross-entropy  
CHP – casing head pressure  
C<sub>PR</sub> – critical pressure ratio proposed by Ashford-Pierce  
CRISP-DM - Cross-Industry Standard Process for Data Mining  
c<sub>vg</sub> - gas discharge coefficient (0.9)  
c<sub>vl</sub> – liquid discharge coefficient (0.85)  
CW – Champion West  
d – choke orifice (mm)  
DL – deep learning  
DTS – distributed temperature sensing  
EOR – enhanced oil recovery method  
ESP – electrical submersible pump  
FLP – flowline pressure  
FLT – flowline temperature  
FP – frack&pack  
GLR – gas liquid ratio (m<sup>3</sup>/m<sup>3</sup>)  
GOR – gas oil ratio  
HRWP – high rate water pack  
ICD – inflow control device  
ICV – inflow control valve  
IOR – improved oil recovery method  
IPR – inflow performance relationship  
LWD – logging while drilling  
ML – machine learning  
MPFM – multiphase flow meter gauge  
MTM – metal to metal seal  
MWD – measurement while drilling

NN – neural networks  
OGR – oil-gas ratio  
PDG – permanent downhole gauge  
PTA – pressure transient analysis  
 $p_{up}$  – pressure upstream to the choke (bar)  
 $q$  - total mixture flowrate ( $m^3/s$ )  
 $q_l$  – liquid flow rate ( $m^3/s$ )  
RNN – recurrent neural network  
ROC – receiver operating characteristics  
RTU – remote terminal unit  
SCADA – supervisory control and data acquisition system  
SOV – solenoid-operated valve  
SSSV – subsurface safety valve  
TEC – tubing encapsulated conductor  
THP – tubing head pressure  
THT – tubing head temperature  
VLP – vertical lift performance  
WGR – water-gas ratio  
 $Z_g$  – gas compressibility factor  
 $Z_l$  – liquid compressibility factor  
 $\gamma$  – gas specific gravity  
 $\Delta P$  – pressure loss across the choke (bar)  
 $\lambda_g$  – gas flowing fraction  
 $\lambda_l$  – liquid flowing fraction  
 $v$  – mixture velocity ( $m^2/s$ )  
 $\rho_g$  – gas density ( $kg/m^3$ )  
 $\rho_l$  – liquid density ( $kg/m^3$ )  
 $\rho_n$  – non-slip density ( $kg/m^3$ )

## 1. INTRODUCTION

The challenges in the oil and gas industry are becoming bigger as there is a need to economically produce hydrocarbons from more complex reservoirs and attempt to increase ultimate recovery at the same time. Engineers have found solutions for better well placement by obtaining higher resolution data by using measurements while drilling (MWD) and logging while drilling (LWD). However, good well placement and production rates alone do not give a good project. The need to improve the recovery of hydrocarbons has shown to be more difficult and essential for successful oil and gas industry. Reservoir management and completion technology have a big impact on ultimate recovery, and more complex reservoirs discovered around the world demand special multiple zone completions. As the production parameters change over the lifetime of a well, it is necessary to have completion that can modify its configuration to achieve optimal production. The special completion technology that is remotely controllable and able to optimize the production process in real-time is called intelligent completions. Intelligent completion includes downhole sensors, actuators, and software which allows intelligent completion operator to actively monitor, remotely control or shut selected zones with a bad performance from the operation centre, without traditional intervention on certain well. Application of this advanced technology can prevent early gas or water breakthrough, manage water injection for pressure maintenance or control chemical injection and placement.

Nevertheless, implementation of intelligent completion, besides advanced technology and equipment, requires integration of different disciplines such as reservoir engineering, production engineering, petrophysics, data science, and data engineering. For a successful application of new technology, it is essential to collect, organize and analyse the data. To be able to make a decision, one needs to fully understand hidden trends and correlations in a particular operation. The aim of this thesis is to consider the possibility to manage and control intelligent equipment in a way to reduce human interaction and to automate wells by machine learning. Implementation of machine learning is just one of several data mining tools. According to Eldestein, the data mining process can be defined as: „A process that uses a variety of data analysis tools to discover patterns and relationships in data that may be used to make valid predictions.” After thorough big data analysis, one is ready to extract key performance indicators which will give an answer on which operation or equipment should be focused on. Till now, software in intelligent completions was working based on algorithms that engineers have to put in the system. If machine learning

is applied, algorithms are changed by the principle of self-learning. In other words, machine learning is designed to emulate how the human brain works. In this case, the software will not be programmed but it will learn from training samples, and after training it can provide solutions for similar problems.

In this research, data mining will be performed on a gas well located in Croatia. The aim is to give a solution for intelligent completion for well after detailed data analysis. Afterward, the goal is to combine neural network system with intelligent equipment.

## 2. INTELLIGENT COMPLETION

The intelligent well system is a type of completion which provides system monitoring, fluid production or injection control, and optimization. Nowadays, operator companies that have deployed intelligent completions can make decisions based on real-time data about production or injection processes in complex reservoirs and wells with multiple zones completion. The intelligent well system enables to reach several reservoirs with just one well avoiding crossflows. Usually, in case of multiple zones, the completion was completed with several packers and several tubings. If that was not possible due to economics or feasibility, then a sequenced production was applied meaning the production started from the bottom and then moved to upper zones as the lower ones were depleted. Intelligent completion can save time by balanced commingled production from lower and upper production zones and total production can be accelerated. In addition, well interventions are reduced by the possibility to remotely change flow paths and improve reservoir performance which is especially important in subsea, multilateral or unattended platforms (Gao *et.al*, 2007). However, there is still room for improvement as in smart wells there is more and more data available and a big part of it is still not efficiently used.

Advantages of intelligent completion in comparison to conventional completion are (Glandt, 2003; Bellarby, 2009; Correa *et al.*, 2017):

- Reduced tubing interventions by remote actuation of downhole valves;
- Increased reservoir information by shutting in one zone and flowing the adjacent interval;
- Better zone (area) selection for chemical placement;
- Better gas/water injection control;
- Alternating production from one interval with another;
- Fast response to unexpected changes in production or injection operations;
- Increase in ultimate recovery because of better reservoir management;
- Reduced cost and risk of zonal isolation.

On the other hand, the disadvantages of intelligent completions are (Abdullayev *et al.*, 2017):

- Significantly higher costs;

- Plugging and damage of inflow control device (ICD) and/or inflow control valve (ICV) due to debris, scales, and emulsions which results in bad performance;
- Transmission and control loss due to mistakenly coupled communication and power lines;
- Data recorded on the sensors is not processed significantly and that opens new possibilities.

## 2.1. Application of intelligent completion

According to Carvajal *et al.*, 2018, there are several reasons why and when to install equipment for intelligent completion:

- Gas and water flow control. Preventing early water or gas breakthrough is one of the main reasons why to apply intelligent completion technology. ICDs or ICVs are installed to equalize the flow and create necessary pressure drop, especially in horizontal wells due to toe-to-heel effect. If water cut or gas-oil-ratio (GOR) is too high, the zone can be completely shut off and production from other zones can undisturbedly continue;
- Commingled production. Using only one well thus having a smaller footprint, smart well can produce from several reservoirs and layers at the same time. In case water breakthrough occurs in an individual layer, packers, and ICVs can isolate it, control it and obtain desired oil cut;
- Auto lift injection. In case there are gas layers on top of oil-bearing zones, intelligent completion can easily manage production. If ICV is installed in upper layers, the produced gas volume is controlled to lift oil to the surface easily. In addition, if there is water in the upper layers, it can be reinjected to the oil-bearing zone to boost the reservoir energy. This is called water-dump flood method;
- Optimization of enhanced oil recovery (EOR) or improved oil recovery (IOR) methods. ICVs can be used in water injection wells and distribute injected water to gain better sweep efficiency. ICVs can control production and injection per segments and manage permeability variations;
- Well test. Intelligent equipment includes pressure and temperature sensors that provide real-time data. Therefore, pressures can be easily analysed, time for pressure buildup tests is minimized and production is accelerated.

## 2.2. Components of an intelligent well

Basic components of an intelligently completed well are shown in figure 2-1 and consist of (Shaw, 2011; Gao *et al.*, 2007):

- packers,
- surface and downhole gauges and sensors,
- control, communication and power cables,
- flow control devices (ICV and ICD),
- surface control system.

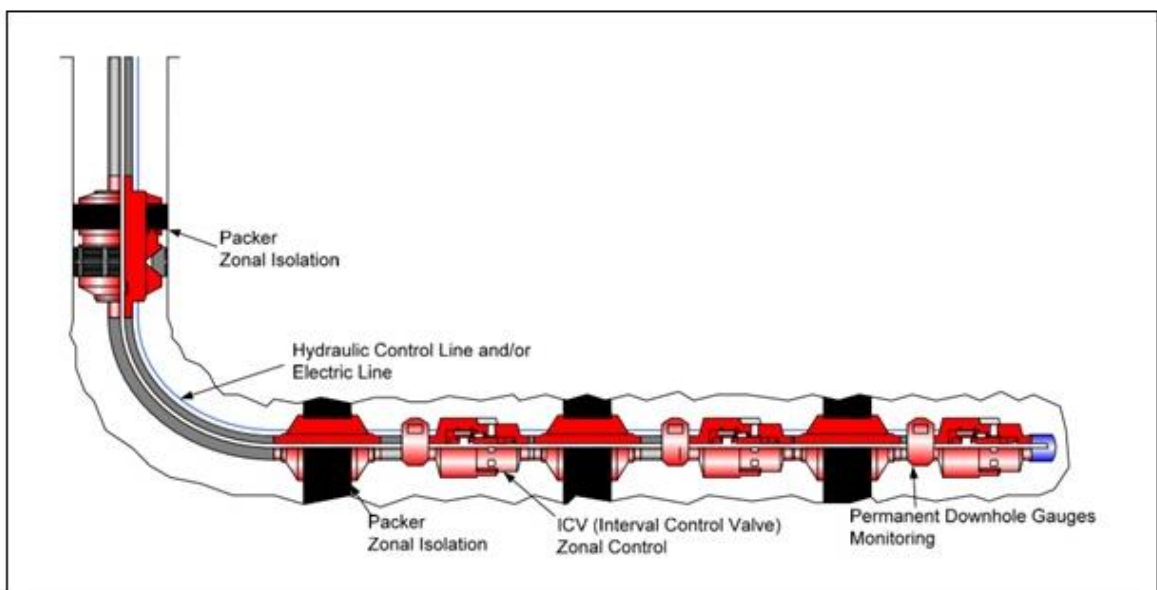

Figure 2-1. Downhole components of intelligent completion (Shaw, 2011)

### 2.2.1. Packers

Packers are part of the completion equipment used to isolate different zones. The zones can be different reservoirs or different layers in the same reservoir. They provide isolation between the production string and casing or open hole. In intelligent completion, it is necessary to consider the packer with bypass for control lines.

### 2.2.2. Surface and downhole gauges and sensors

When intelligent equipment is installed, intelligent completion operator is able to monitor permanent downhole gauges (PDGs) and operate and control interval control valves



from the surface control and monitoring system. Data is transmitted from the downhole gauges via cables to the surface where real-time monitoring and control takes place.

#### *2.2.2.1. Downhole gauges*

The monitoring of the operations is performed by permanent downhole gauges (PDG) and distributed temperature sensing (DTS). These sensors can measure several parameters such as flow rate, pressure, and temperature. Based on the parameters, decisions for production or injection operations can be made. PDGs use a tubing encapsulated conductor (TEC) as an electrical return path to the surface. A PDG consists of conductive wires with thermoplastic insulation. In the case of DTS, fiber optic cable is used instead of conductive wire (Shaw, 2011). The flowrate measurements are based on the Venturi system or pressure differences between flow control devices. Furthermore, new sensors and measuring devices are being developed such as density meters, water cut sensors, chemical analysis sensors, and resistivity measurement devices. During well shut-in, downhole gauges are very valuable because they can record data for pressure transient analysis (PTA) and data such as static reservoir pressure, skin factor and reservoir conductivity can be estimated. Depending on the type of artificial lift system, gauges are positioned at different places. In case of a gas lift, the downhole gas valve is used and based on pressure difference estimates the flowing pressure in the tubing and injected gas. Electrical submersible pumps (ESPs) usually have downhole intake pressure gauge (before the motor) and discharge pressure gauge (after the pump) and temperature sensor. In wells without artificial lift system, that produce naturally, it is recommended to set the gauges at the end of the tubing (Carvajal *et al.*, 2018).

#### *2.2.2.2. Surface gauges*

There are several available gauges and some of the most important surface measurements are pressure and temperature. Surface monitoring includes tubing head pressure, tubing head temperature, casing head pressure (if wells produce through annulus), flowline temperature and flowline pressure. In addition, a permanent downhole monitoring system can be connected with multiphase flow meter gauges (MPFM) at the surface. The

MPFM gauge monitors three-phase flow at the surface and is used as an alternative to the separator and individual flowmeters (three flowmeters for each phase). Usually, it is found after the wellhead and before separator (Carvajal *et al.*, 2018).

### 2.2.3. Control, communication and power cables

The power necessary to control inflow control valves comes from an electric source, hydraulic source or combination of both. In the beginning, the intelligent completion system relied on the electric system. The need for increased reliability and lower costs led to hydraulic systems. These systems provide better flow control (greater openings and bigger closing forces) and are more suitable in harsh well conditions. However, in comparison to a hydraulic control system, both electro-hydraulic and electrical control lines have some advantages. They have faster response time and a smaller number of control lines. On the other hand, disadvantages are temperature sensitivity and unavailability of the system due to breaks in the electrical line (Garcia and Saldanha, 2016). Usually, the control lines are encased in a metal tube as a protection usually called tubing encased conductor (TEC). A solid copper inside TEC allows two-way communication between permanent downhole gauges and surface and provides power (Hodges, 2000). Electric, hydraulic and fiber optic lines have standardized outside diameter is 6,35 mm (¼ inch) (Shaw, 2011).

#### 2.2.3.1. Hydraulic control system

The hydraulic control system, also called direct control, uses two lines from the surface for one ICV. One hydraulic line is connected to “open” side, another to “close” side of a piston of the ICV. By applying pressure on one of these sides, the piston will move and result in opening or closing the ICV. In the case of multizone completion, when more than two ICVs are necessary, N+1 hydraulic lines are required (N is number of ICVs). In this case, the open side of ICV has an individual hydraulic line, while the closed hydraulic line goes from one ICV to another. However, there is a limitation of the number of used hydraulic lines due to available tubing hanger openings and enlarged costs with every additional line. It has to be taken into consideration that other intelligent equipment like gauges can also require control lines. Therefore, in multizone completions when there are more than two zones, as an alternative, electro-hydraulic or electro-mechanical line can be used. In figure

2-2 it is shown how many hydraulic lines would be necessary to manage ICVs in three zones (Garcia and Mathew, 2016).

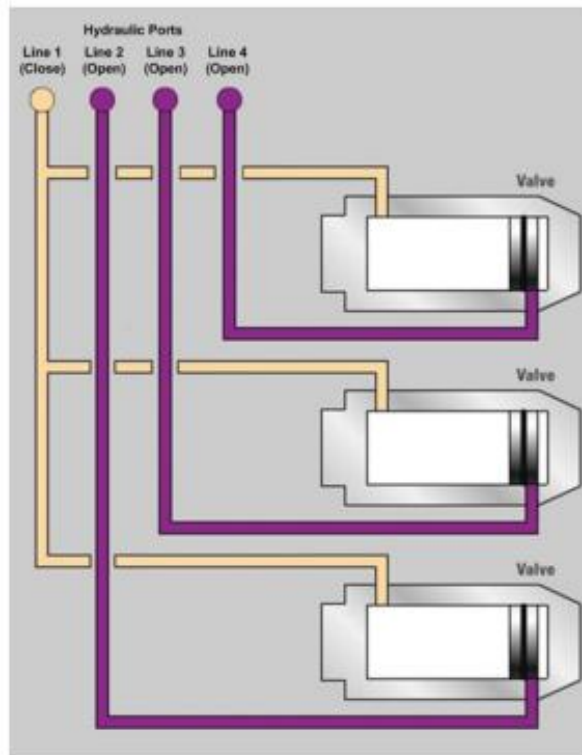

Figure 2-2. Three-zone intelligent completion with hydraulic control system N+1 (Garcia and Mathew, 2016)

### 2.2.3.2. Electro-hydraulic control system

The electro-hydraulic control system uses fluid to control and manage ICV movement as it is used in a completely hydraulic control system. However, the principle of working includes final opening or closing the valve electronically through the solenoid valve (figure 2-3). One electric and two hydraulic lines can control up to twelve zones. If the operator wants to open or close ICV, particular hydraulic line (depends on which operation-opening or closing) will be pressurized from the surface. The “open” or “close” line will be blocked at the end until the operator electrically chooses particular ICV. Furthermore, the selected module will activate a solenoid-operated valve (SOV) which will let the pressure to the piston chamber of particular ICV. After the desired movement of the ICV is achieved, the removal of the electric current from the module will disengage SOV. It is possible to perform the movements of other ICVs without removing hydraulic pressure. In addition, valves can be regulated to have a different position between completely “open” or “closed”

position by controlling the fluid volume. It is necessary to account temperature changes because it can affect hydraulic fluid that actuates the system. However, the electro-hydraulic system allows recalibration even after the system is installed so, in case of big temperature difference, this effect can still be mitigated. A big advantage of this system is faster overall response and possibility that with only three lines, twelve different zones can be controlled. In the end, this reduces overall costs (Garcia and Mathew, 2016).

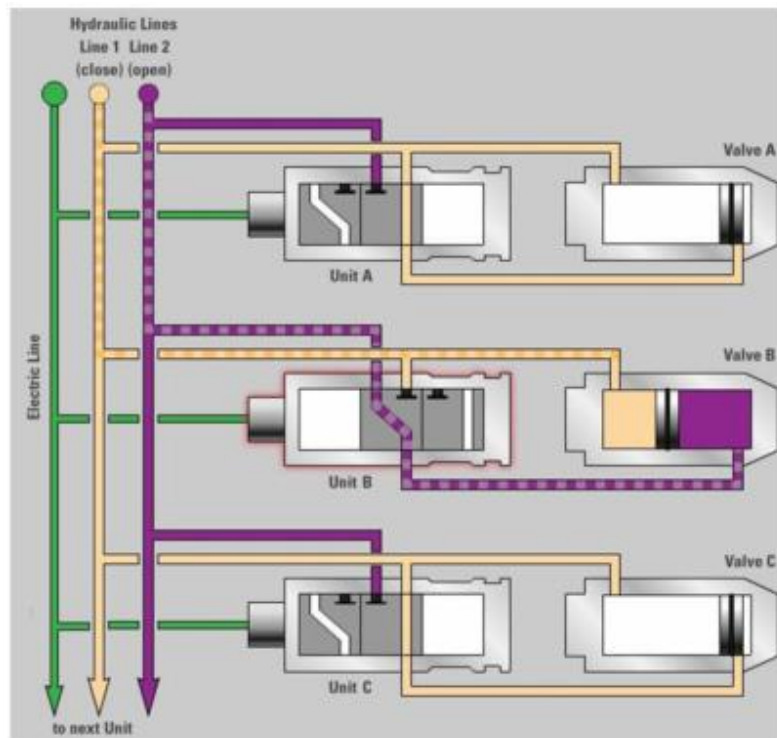

Figure 2-3. Three-zone intelligent completion with the electro-hydraulic system (Garcia and Mathew, 2016)

### 2.2.3.3. Electric control system

The electric or electromechanical control system is the first generation of ICV control and consists of only one electrical line that is connected to each ICV. Each ICV is connected to electrical motor and gearbox for the purpose of converting radial motion to linear motion. When the operator selects particular ICV, current flows to particular motor and motor moves clockwise or counter-clockwise depending on the current polarity. After the opening or closing is done, the motor is shut off by switching the power off. This type of control system provided poor force for ICV opening and closing and was not suited for dealing with debris and scale (Garcia and Mathew, 2016).

#### 2.2.4. Flow control devices (ICD and ICV)

In conventional wells, hydrocarbon production rates are controlled by wellhead choke or in production flowline. Besides production rates, by adjusting the surface choke, water or gas coning and depression are controlled. This way, drawdown pressures can be reduced, and production rates decreased. The result is an increased cumulative oil recovery. However, this procedure is not working in horizontal or multilateral wells. In long horizontal sections of a homogenous formation, the significant pressure drop will happen as fluids flow from true depth to heel of the well (end of vertical section). This effect is known as the heel-toe effect shown in figure 2-4 and figure 2-5 where green colour represents oil, red gas and blue water. In heel-toe effect, the drawdown at the heel is much higher than at the toe causing water and gas coning and resulting in economically unprofitable well production due to high water cut. Early water or gas breakthrough can also happen in compartmentalized reservoirs and carbonate reservoirs due to a large number of natural fractures or because of the interference from injection and production wells. In intelligent well, inflow control device (ICD) and/or inflow control valve (ICV) are used to deal with that problem. The difference between these two is that ICD is passive control, part of the liner or casing, while ICV is active control (Ellis *et al.*, 2009). Available sizes of ICV and ICD for certain hole sizes are shown in table 2-1.

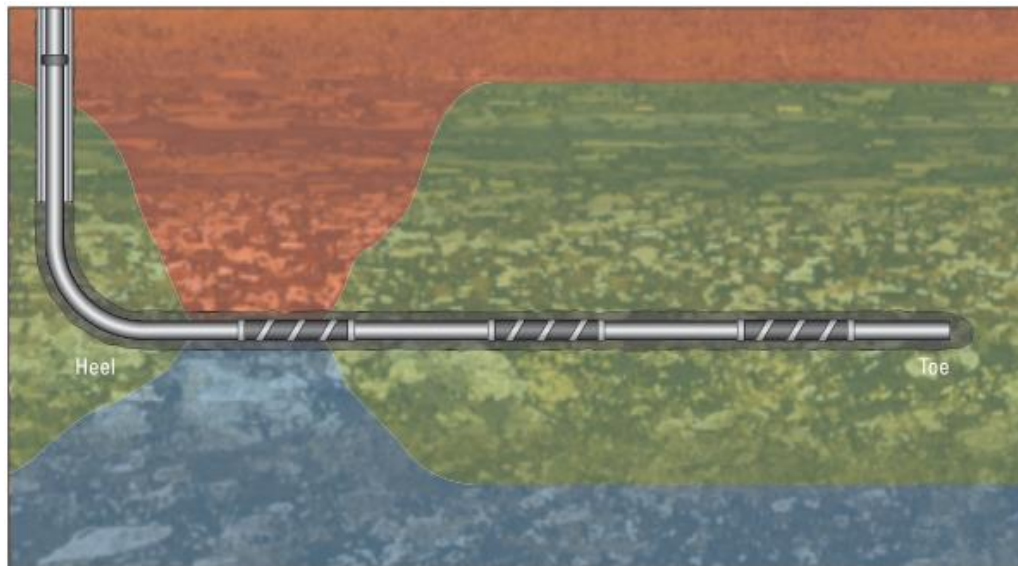

Figure 2-4. Heel-toe effect in a horizontal well. Beginning of water and gas coning (Ellis *et al.*, 2009)

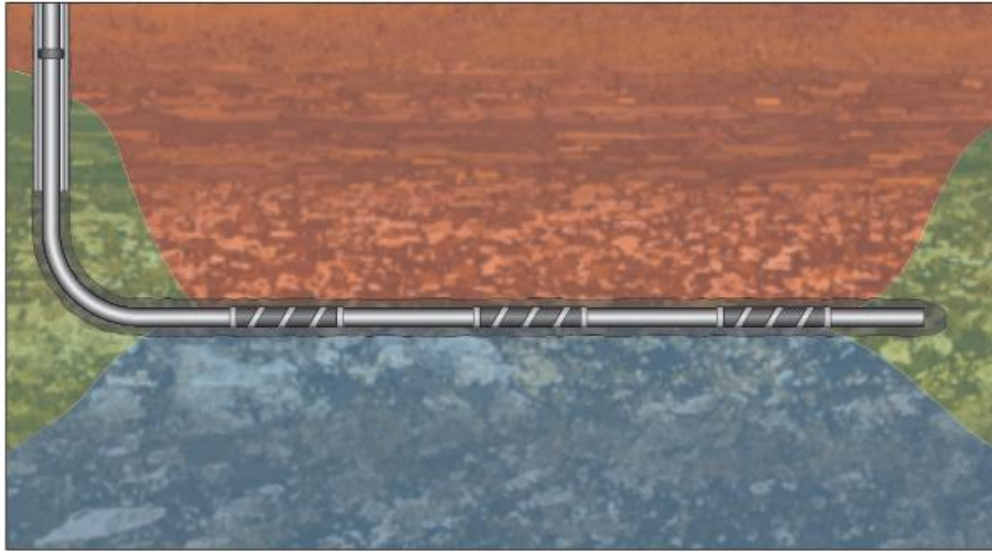

Figure 2-5. Heel-toe effect in a horizontal well. Advanced water and gas coning (Ellis et al., 2009)

Table 2-1. ICD and ICV sizes for certain hole size (Birchenko, 2010)

Hole size, mm (in)	OD ICD flow conduit, mm (in)	OD cased hole ICV flow conduit, mm (in)	OD open hole ICV flow conduit, mm (in)
149,23 (5 7/8)	88,90 (3 1/2)		
165,10 (6 1/2)		73,03 (2 7/8)	88,90 (3 1/2)
200,03 (7 7/8)	139,70 (5 1/2)		
215,90 (8 1/2)		88,90 (3 1/2)	
241,30 (9 1/2)	168,28 (6 5/8)		139,70 (5 1/2)
269,88 (10 5/8)		114,30 (4 1/2)	

#### 2.2.4.1. Inflow control device (ICD)

ICD is a permanent part of equipment installed in the well with different designs of flow path causing an additional pressure drop. It provides a uniform flow of oil/gas along whole wellbore length enabling delayed arrival of water and gas. ICDs are mostly part of open hole completions including sand screens. There are two types of ICD available: conventional ICD and autonomous inflow control device (AICD). Conventional ICD is used to equalize fluid flow from toe to heel and choke unwanted fluids such as water or gas (figure 2-6). However, they still produce big amounts of unwanted fluids. Therefore, autonomous ICD is installed to choke unwanted fluids even more and reduce their production based on

centrifugation principle or density difference. AICDs have a self-regulating mechanism in which they are able to control fluid flow through internal discs (figure 2-7). Water takes a longer path while oil takes shorter resulting in restricted mass flow of water (Carvajal *et al.*, 2018).

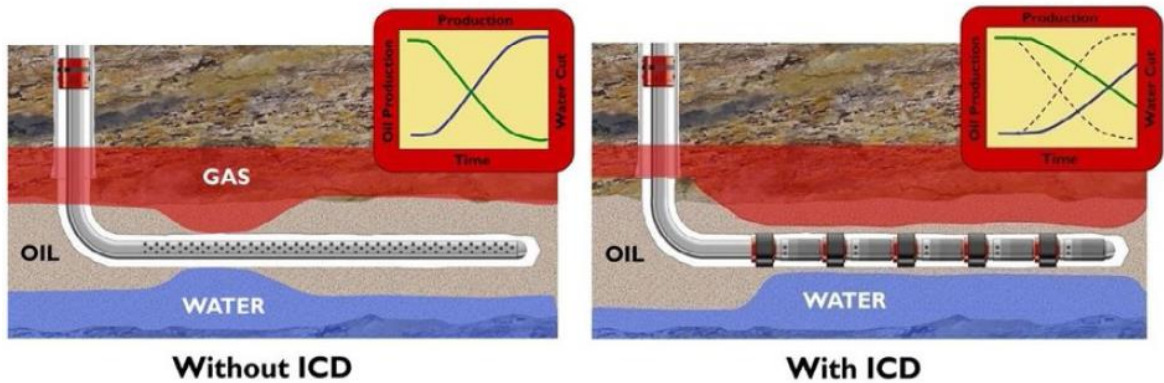

Figure 2-6. Comparison of completion with and without ICD and water and gas front respectively (Carvajal *et al.*, 2018)

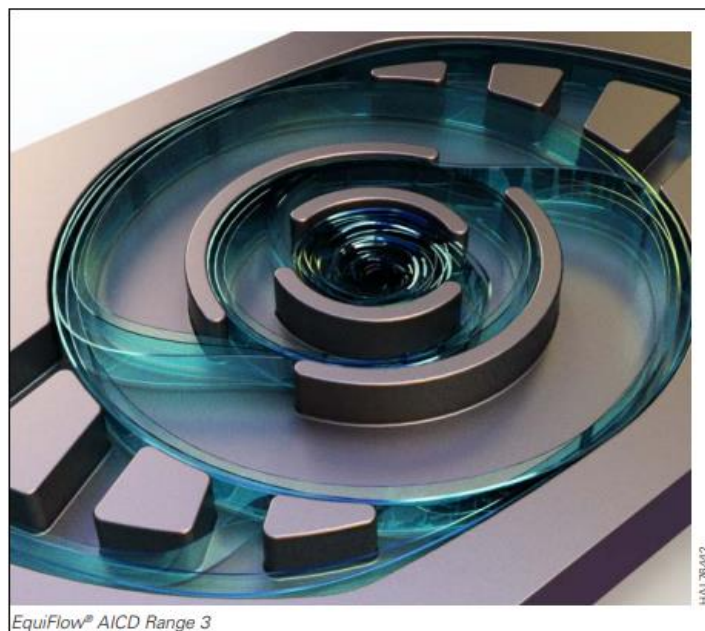

Figure 2-7. Autonomous inflow control device Equi Flow by Halliburton (<https://www.halliburton.com/>)

Two important features that are desirable in ICDs are erosion and plugging resistance. Once they are installed, ICDs are not adjustable. That makes their installation and completion design critical for production. Proper design and installation of ICDs require a thorough analysis of initial reservoir conditions, predictions of reservoir behaviour and

reservoir simulations but they are more reliable and simpler than ICVs. However, having on mind that reservoirs conditions are dynamic, it is often necessary to have device adaptable to changes in viscosity, velocity, density with time and to keep inflow balance (Ranjith *et al.*, 2017).

There are several types of conventional ICDs in the industry developed by different vendors. Usually, conventional ICDs can be classified into three categories: channel type, orifice type and nozzle type (Ranjith *et al.*, 2017).

Channel type (figure 2-8) has numerous helical channels which at specific flowrates give specific differential pressures. The formation fluid flows through the annulus into screen layers that are on the inner jacket. Afterward, fluid flows towards the ICD chamber along the screen base pipe. In ICD, designed number of channels will cause choking and then fluid goes to the inner part of the casing. Channel type creates pressure drop based on friction which means that it can be affected by emulsion effects. However, the chance of erosion and plugging is reduced due to channel design which causes pressure to drop over a larger interval in comparison to orifice and nozzle type (Al-Khelaiwi and Davies, 2007).



Figure 2-8. ICD helical-channel type (Al-Khelaiwi and Davies, 2007)

Nozzle type (figure 2-9) creates a pressure drop by using nozzles. The fluid flows through the screen towards a set of nozzles and afterward to the inner part of the tubing. The desired pressure drop at certain flowrate is achieved based on a specific number and diameter of the nozzles. In this type of ICD, pressure drop depends on the density and velocity of the fluid and less on the viscosity. However, the possibility of erosion is very big as one of the major causes is the high velocity of the fluid. In the case of high sand production this problem is aggravated (Al-Khelaiwi and Davies, 2007).



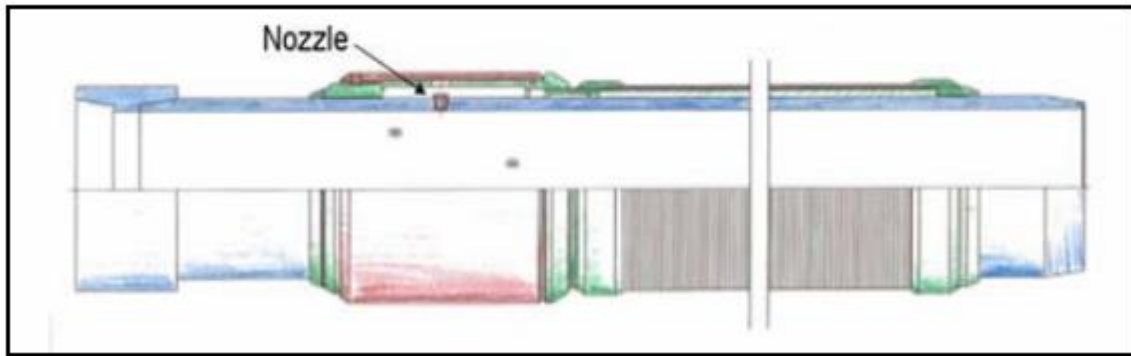

Figure 2-9. ICD nozzle type (Al-Khelaiwi and Davies, 2007)

Orifice type (figure 2-10) employs numerous orifices to obtain the desired pressure drop. Orifices have a specific diameter and flow characteristics to enable required flow equalization. The base pipe in ICD chamber is surrounded by a jacket in which orifices are integrated. The required pressure drop is regulated by the number of open orifices (Al-Khelaiwi and Davies, 2007).

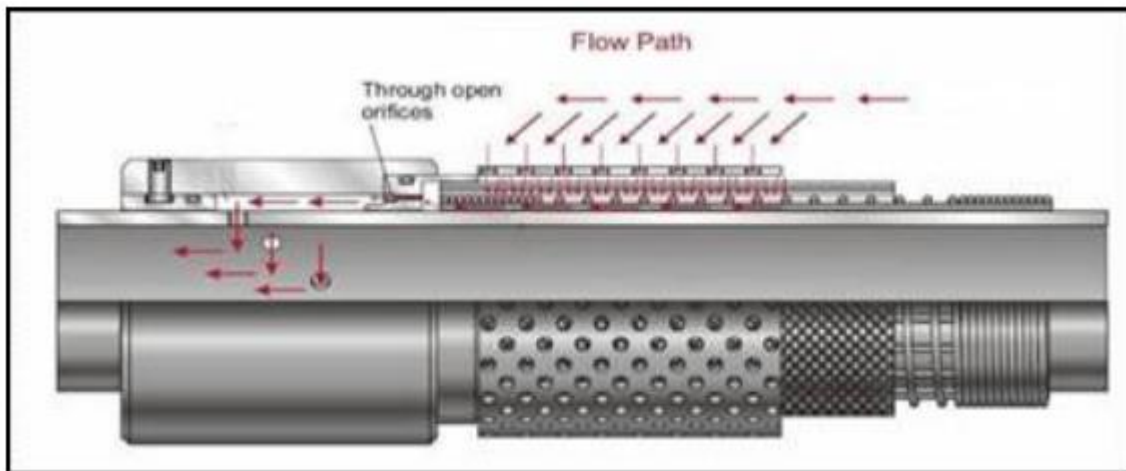

Figure 2-10. ICD orifice type (Al-Khelaiwi and Davies, 2007)

Although there are several different designs of ICDs, the principle of working is the same. By creating differential pressure, they are trying to equalize the flow. However, they are not flexible, and some risks are associated with their application. ICDs can get plugged or damaged due to mud, scales, asphaltenes or emulsion. Moreover, they can be corroded if carbon dioxide is present while producing fluid (Ranjith *et al.*, 2017).

#### 2.2.4.2. Inflow control valve (ICV)

As reservoir uncertainties are getting higher, more adjustments and flexibility is required. Therefore, ICVs can be used to provide more flexible strategies in field development. ICV is a tool that allows communication between tubing and annulus and provides control in the operations based on the information from permanent monitoring. Regarding functionality there are two types of ICVs (Shaw, 2011): on/off ICVs and choking ICVs. The first type provides communication with the zone or it selectively shuts in zones and presents a much cheaper solution but has limited settings. The choking ICVs have different port sizes and it is possible to adjust them in different positions. The number of positions varies and ICV can have 2, 4, 6, 8 or even 11 choking positions (<https://www.slb.com/completions/well-completions/intelligent-completions/downhole-interval-control-valves>). Depending on the design, the price will also vary and for example electrically controlled ICV can cost up to \$0,5 million per valve (Ranjith *et al.*, 2017). In multi-lateral wells, each layer can have different permeability, therefore, water breakthrough happens at different time. By using ICVs, each interval can be shut off when water or gas breakthrough happens to prevent the early end of well's production.

The first type of ICV (figure 2-11) available on the market consisted of the following components (Joubran, 2018):

- metal to metal (MTM) face seal from tungsten carbide;
- tungsten carbide choke in 10 different positions;
- micro hydraulic device that has the purpose of precise opening of ICV to the desired position and at the same time has the ability to completely close the ICV;
- ICV installed in injectors are additionally equipped with tungsten carbide lined deflectors to prevent erosion of casing.

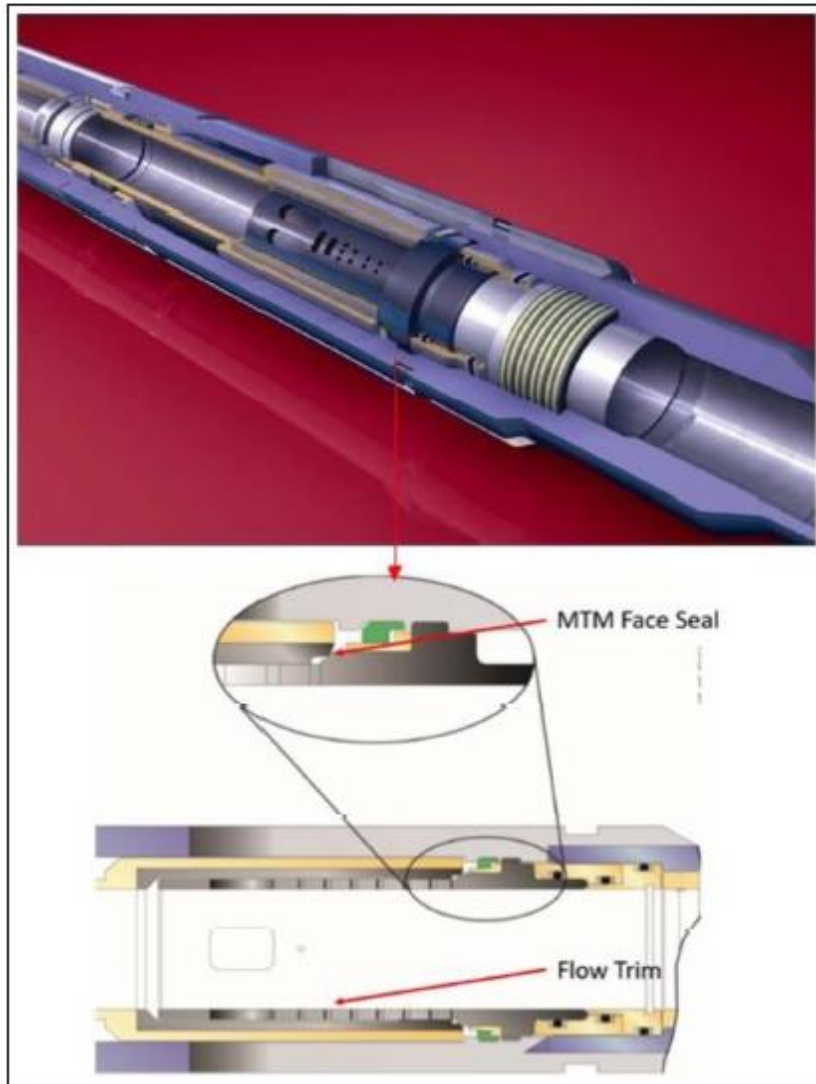

Figure 2-11. First type of ICV (Joubran, 2018)

The first type of ICV had two typical issues that cause loss of zonal control. The first problem is control line failure that is mostly due to high-rate injections. The second very common problem was stuck ICV due to precipitations like scale or debris. Also, in the first generation of ICVs, MTM seal was a common issue. This type of face seal required a boost system to achieve complete pressure retention.

Based on many campaigns and field implementation of firstly developed ICVs and lessons learned, the goal was to design new ICVs which will combine best practices. The newest developed ICV (figure 2-12) consists of the following components (Joubran, 2018):

- pressure balanced mandrel,
- radial interference metal to metal seal,

- hydraulic chamber seals (hybrid elastomeric and non-elastomeric),
- deflector and control line integration,
- flow trim (tungsten carbide shrouded) with 8 different positions,
- ability to send to the surface information about choke position and opening in real-time.

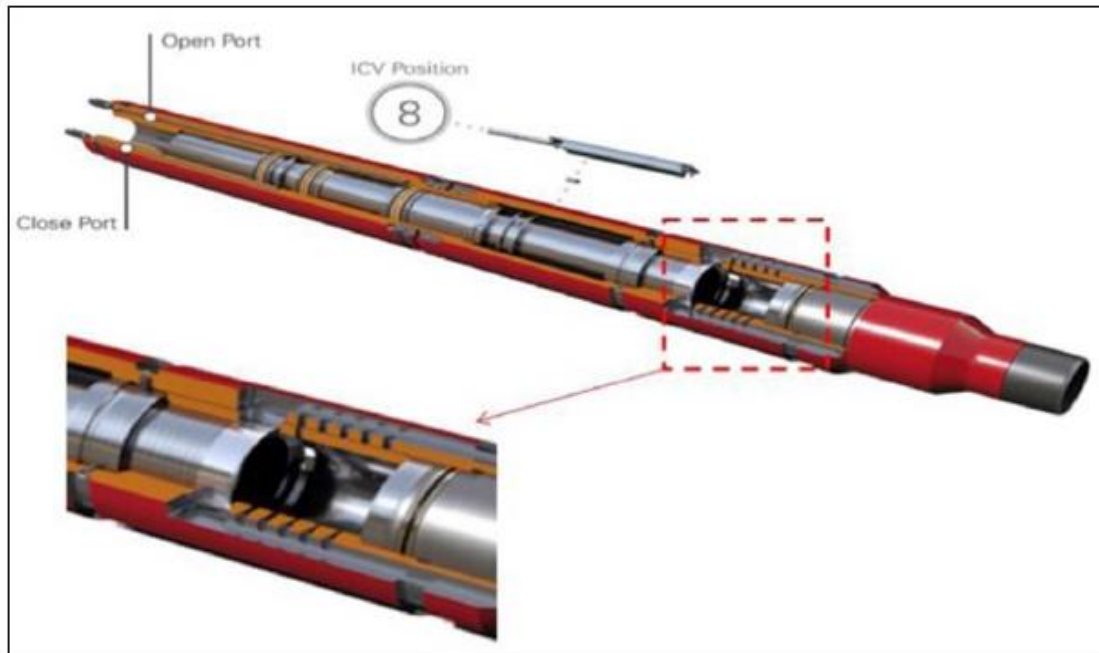

Figure 2-12. Newly developed ICV (Joubran, 2018)

The complexity of ICVs was reduced by changing face MTM seal to radial interference MTM seal, therefore, there is no need for the boost system anymore. In the new design of MTM seal, the mandrel can liberate from the seal when ICV is at different choking positions which results in big unloading in every direction.

Special attention should be given to the production fluid chemistry. As in many wells, problems such as wax, asphaltenes, and scales occur, the ICV design and functionality should be planned accordingly (Joubran, 2018).

#### 2.2.5. Surface control system

The downhole equipment is connected by cables through the tubing with a surface control system. Pressure and temperature data are sent to the surface control panel in real-

time. From control panel data is sent to supervisory control and data acquisition (SCADA) system. Based on the flow rate model, the decision about ICVs openings is made and sent back to the control panel. In figure 2-13 it is shown how information from downhole gauges is sent to the surface monitoring system where decisions are made in real-time.

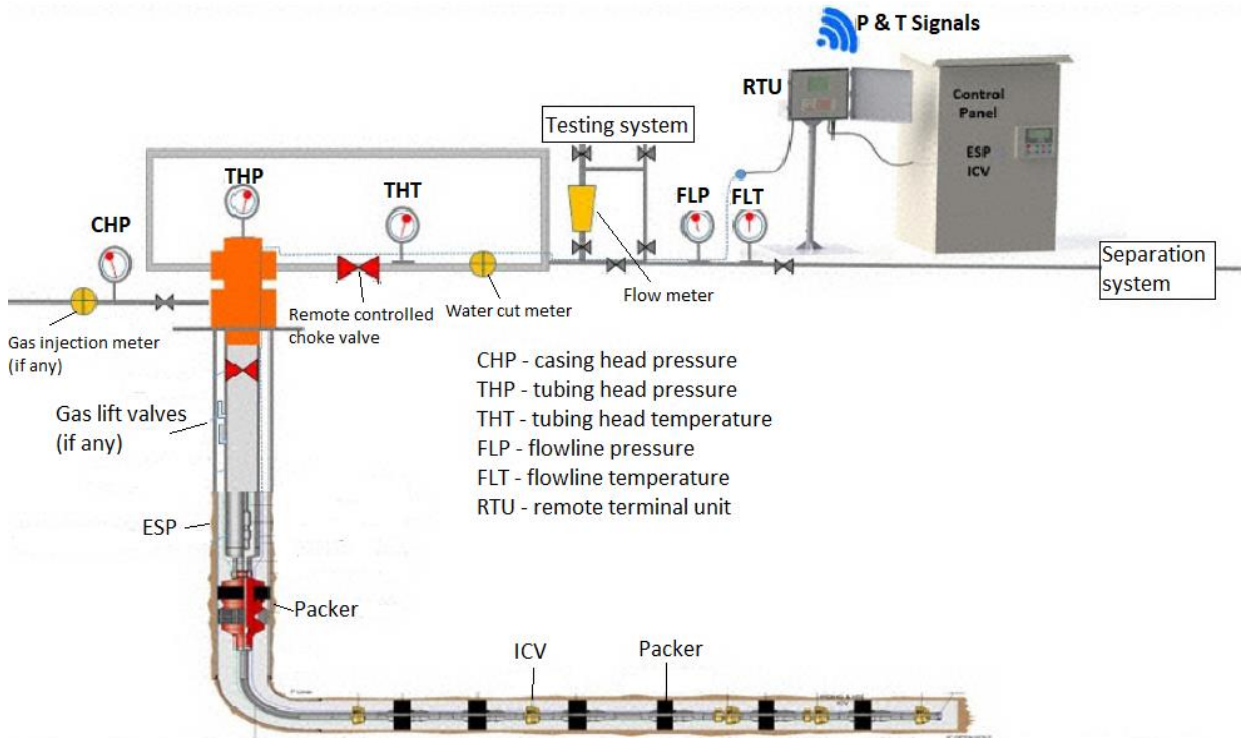

Figure 2-13. Scheme of a smart well and how surface and downhole gauges are connected to the surface monitoring system (Carvajal et al., 2018)

### 2.3. An example of evolution from smart wells to a smart field in Brunei, Champion West offshore field

Champion West (CW) offshore field in Brunei waters was accidentally discovered in 1975. First, the intention was to use a new well as gas supply to Champion Main field, but oil was discovered as well. Several field development plans were made but the complexity of the field was obvious (10 fault blocks with erratic charge needing a lot of wells and platforms) and it was difficult to choose an economic and feasible plan. The first attempt was in 1998 but was soon abandoned after drilling problems. After that, it was decided to make a field development plan in several phases.

The new approach consisted of three parts: a novel well concept, smart well technology, and extended reach drilling. It was planned to have only one platform with 20 wells. It was agreed to develop CW field as a smart field meaning the field will be constantly and completely monitored, remotely controlled and operated. The data (pressure, temperature, flow rate) will be collected and then analysed by the operator. The field development team concluded that only way to achieve successful smart field implementation is phased staircase approach. They planned three phases. Phase 1 was from 1999 till 2000 and it was an introduction in the smart well technology. Phase 2 was 2003/2004 in which they upgraded the system with remote control of inflow control valves (ICVs). Finally, phase 3 was in 2005 when the smart platform was installed.

Phase 1 covered the installation of first intelligent completion equipment with permanent downhole gauges and hydraulic ICVs. The equipment installation was successful with only one ICV failed out of 13. With all the data coming, it was necessary to create a team of people from all departments (from IT to the field operators). The task was to monitor, detect faults, report errors and maintain the system. The very important step in field development was smart field training for the operators as before, only contractors and office petroleum engineers were skilled in how to open/close ICVs. Company *Shell* developed the Data Acquisition and Control Architecture Standard. In the beginning, a lot of data was coming into the office making it a problem. It was necessary to distinguish noisy data by using the right software to filter it and to not get lost in the abundance of data.

In phase 2, extended reach horizontal “snake” wells were drilled (to 6 km length and 3 km reservoir sections). The wells are called snake wells because they have tortuous in a narrow oil rim with right/left turnings but staying in the horizontal plane. It was a challenge to drill snake trajectory wells keeping the dogleg severity under 1deg/10m to not to go too far out of the zone of interest. The inflow performance for new wells was 10 times greater and the drawdown was from 1 to 10 bars. The multitude intelligent completion showed notable pressure losses at high rates in a stinger. The stinger is a piece of pipe installed in horizontal sections of the well to reduce water coning and redistribute pressure losses in horizontal wells. In the first phase stinger used was 73,03 mm (2 7/8”) in 139,7 mm (5 1/2”) slotted liner. In phase 2 it was increased to 88,9 mm (3 1/2”) in 168,28 mm (6 5/8”) liner. Finally, in phase 3, 114,3 mm (4 1/2”) stinger was used in 177,8 mm (7”) slotted liner. In the heel section, the friction was still significant and with the use of open/close valve this zone would be overproduced. By use of ICVs, it was possible to manage frictional pressure losses. With variable ICVs and software implementation, it was possible to maintain equal

drawdowns in different zones but the ICV position changes were done manually. Finally, the old facility was upgraded. Power and fiber optic cables were installed as well as the downhole control system to control the smart field. In addition, facilities were upgraded to be able to remotely read out the sensors.

The last phase presents the CW field as a fully developed smart field. That includes a remotely operable, monitored field with remote shut down and remote re-start facility capability. The smart wells in CW field have more pay zones, longer reservoir sections, longer trajectories, and more multilaterals. The platform still has a room for drilling an additional 30 wells. Also, swellable packers proved to be a good replacement for inflatable packers.

After the smart field development, several conclusions can be made. In offshore application, such as Brunei water, with variable weather (monsoon seasons) and small platforms that are hardly accessible, remote operability presents huge value. Furthermore, the smart field provided better data acquisition, better monitoring and faster response which in the end lead to higher recovery. In CW field it is estimated that the volume recovery increased for 2-3%. Additionally, drilling and completion costs are reduced if for example there is poor casing cementation. The repair job can be substituted by additional packer and ICV close to the heel which will prevent thief gas coming behind the casing. Finally, the important advantage is risk reduction and mitigation (Van der Steen, 2006).

#### **2.4. Value assessment of intelligent well technology**

The crucial thing in the implementation of the new technology in the industry is to properly assess the potential value of the technology. The new technologies have similar approaches to assess the value but in case of smart well technology, it gets more difficult due to the complexity and different interpretations. The estimated benefits based only on the discussions about fewer interventions, better HSE or faster response are not enough. The decision of whether to implement intelligent completion in a well is based on the clear definition of conventional operations with detailed conditions and scenarios. The injection and production criteria need to be defined and with the help of reservoir simulations, comparison of the conventional and intelligent completion systems can be made. Besides technical assessment, economic evaluation should be made. Several things are taken into consideration: incremental capital investments, technically advanced equipment, risk assessment, changes in revenue and the operating costs. The initial capital cost for the

intelligent well system is from US \$ 200 000 for a permanent downhole gauge system up to US \$ 2 500 000 for a fully remote-controlled completion (Robinson, 2003). Although intelligent wells and fields have obvious advantages, there are not so many available results of value identification in terms of money. Every oil company has defined intelligent field differently to tailor it to its strategy and plans. Without a general definition, benefit and value estimation are even more challenging (Husain and Al-Hajri, 2013). However, after thorough analysis, having on mind both costs and revenues, it can be decided is it economical and feasible to implement smart well completion.

#### 2.4.1. Example of value assessment performed by company *Shell*

A value assessment has been made for a period from 2008 to 2009 for Shell Smart Fields in 6 regions, and around 50 assets data were collected (Van den Berg *et al.*, 2010). To have a real picture, values obtained from saved costs or production increase were only looked in that period. Potential future benefits were excluded from the assessment meaning that, for example, future operating costs reduction, production gains or increase of ultimate recovery will not be counted. The value assessment was split into categories:

- production increase,
- ultimate recovery increase,
- CAPEX reduction,
- OPEX reduction.

The smart field development also had HSE benefits but in this case, they were not quantified. A scheme was made to see how solutions generate the value (figure 2-14). In some cases, solutions will provide more than one type of improvement and benefit.



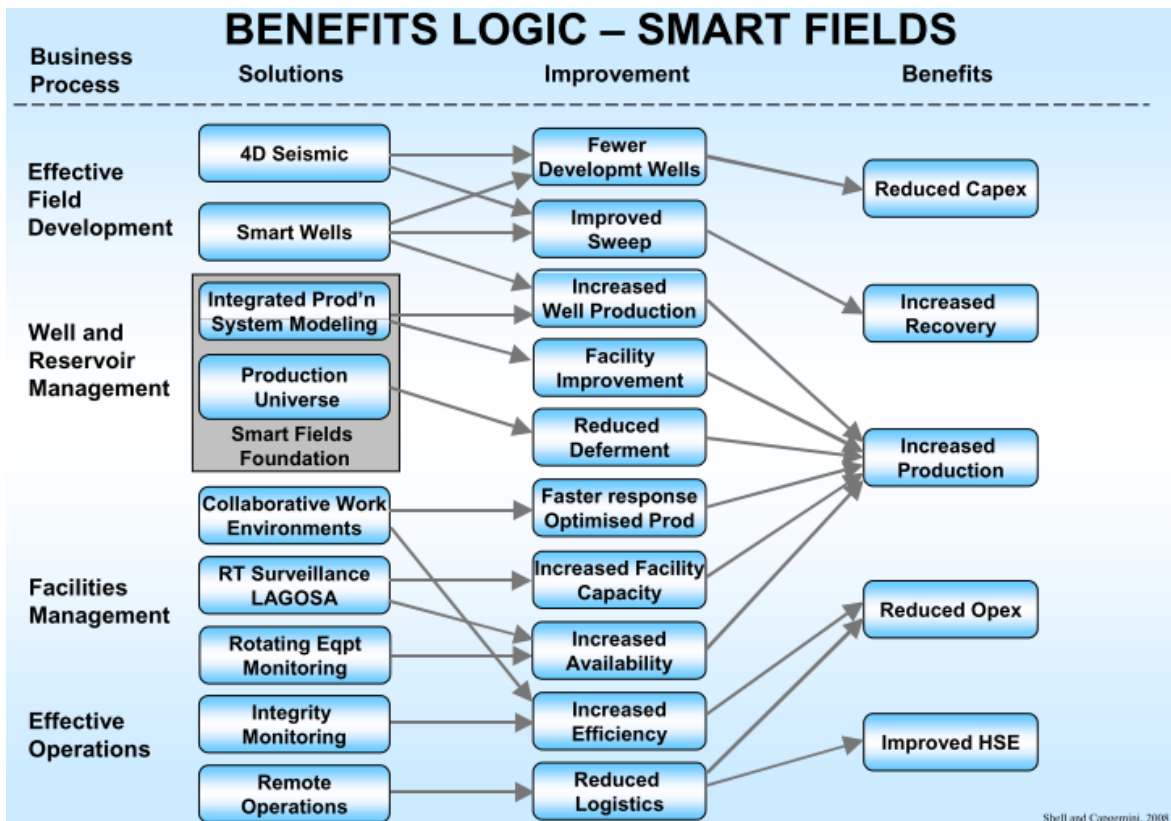

Figure 2-14. Scheme of how Shell smart field improvements and benefits are generated (Van den Berg et al., 2010)

The assessment was made on conservative rules as the objective is to have valid and easy traceable value estimation. The rules include using 30 \$/bbl oil price; only benefits such as saved costs or production gains till the end of 2009 were included. After thorough analysis and quantification, benefits are estimated to \$5 billion. The production increase was 11 129 m<sup>3</sup>/day (70 000 bbl/day) and the total calculated CAPEX reduction was \$800 million. It is also necessary to mention that CAPEX reduction was a one-time benefit while production increase and OPEX reduction can be repeatable. Although retrofitting is complex, costly and possible just for particular problems, the analysis made by Shell for Smart Fields showed benefits both for retrofitting in existing wells and for design from the start in new wells.

The solutions of new technologies provide benefits that in many cases should not be looked separately. It is difficult to completely evaluate benefits and economical value of the new technology but with an early identification in the development process, it can be traceable. A detailed structure and categorization like “Benefits logic” can be very useful in the process of evaluation (Van den Berg *et al.*, 2010).

## **2.5. Challenges of intelligent completion well monitoring and control**

The long-term vision of the intelligently completed well is to make a closed circle between monitoring and equipment that is driven by output from comparing sensor data and reservoir simulations (Robinson, 2003). According to Berg for successful implementation of the smart well system, it is necessary to cover three components: technology, process, and people. In details that means to obtain reliable real-time data, a set of tools to transform that data to information and a team of skilled professionals who use the information to control and optimize operations both on the surface and in the reservoir (Van den Berg, 2007). One of the benefits of intelligent completion is a large amount of the data available. However, this represents a problem as well. In the abundance of the data, an engineer may fail to extract important performance indicators or can even use noisy and unfiltered data. One of the challenges of intelligent completion, besides its complexity and advanced technology, is how to use data properly to transform it into valuable information. By connecting intelligent equipment with machine learning, the goal is not to completely exclude the “people” component. The wanted result is to make easier handling a large amount of data, handle noisy data, filter and organize it and based on it make decisions about operations. However, engineers and operators are still needed and their critical and analytical thinking to react when machine learning models do not give wanted outcomes.

### 3. DATA MINING AND BIG DATA ANALYSIS

With technology development and availability, increased data storage and advanced computational and numerical data analysis, data acquisition and analysis evolved into data mining. According to Zangl and Hannerer, 2003 data mining is defined as “the process of discovering significant new correlations, patterns, and trends by sifting large amounts of data stored in repositories - using pattern recognition technologies as well as statistical and mathematical techniques”. The data mining becomes very valuable in case of the high amount of uncertainties when the conventional type of reservoir monitoring fails in decision-making process and strategy development. The conventional type of monitoring refers to well testing, production data logging, seismic and fluid sampling. In this case, data acquisition timing becomes a big challenge since it is necessary to stop production. Consequently, these processes are usually performed at the time of workover or intervention operations and a description of reservoir production behaviour can be invalid (Temizel *et al.*, 2016). To overcome these problems, intelligent well technology and permanent downhole sensors are becoming more important. In other words, traditional methods of data analysis called knowledge-driven methods have been substituted by so-called data-driven methods. The knowledge-driven method solves problems by applying mathematical equations. The engineer has to know limitations in the application of laws and also make simplifications for more complex cases. In the data-driven methods, the applied mathematical algorithm finds the patterns in behaviour and relationship. From the beginning, data needs to be managed carefully and have good quality control to detect errors or failures. It is necessary to know the origin of data and methods used to obtain them. Data storage or so-called data warehouse has to be well organized because large sets of data are processed, and it is likely to have hidden trends that need to be found. In this data analysis method, it is crucial to have well-prepared data for further analysis.

The process in which data miner will define a target, process data, use data-driven method to analyse it and estimate the result of the mining tools is called knowledge discovery (Zangl and Hannerer, 2003). Data mining process usually consists of three main processes: preparing the data, surveying the data and modelling the data.

The most time in the data mining process is spent on the data preparation. In order to make a good model, it is necessary to have well-prepared data. The objective is to eliminate damaged, outlier or erroneous data. In the next step, the pattern tool is used to find representative data and eliminate out-of-trend data as that can affect the usual pattern.

Afterward, data has to be transformed in a certain form, so it might be necessary to perform calculations. For example, in the case of neural networks input data have to be normalized. In the end, the results have to be transformed back to the initial data form after the calculations. It is important to mention that as the new data is coming to the model, it needs to be adjusted otherwise the model will not work.

As a next step, data survey will determine problems of interest that will be studied and, in the end, optimized. It will not give data evaluation but will provide information about data structure, general relationships, and patterns.

The last step in data mining process is modelling the data which is often directly linked to neural networks. Neural networks are very important modelling tool which will be explained more detailed in the next chapter. Unlike conventional algorithms, neural networks have the ability to be trained to solve a certain task. However, other tools such as self-organizing maps or decision trees should not be excluded from the modelling process.

The three main processes mentioned above can be segregated in more steps to make analysis and modelling easier. The process of analysing and modelling data performed in six phases is done according to CRISP-DM standard (Wirth and Hipp, 2000).

### **3.1. Data mining phases**

According to Larkin and The Cross-Industry Standard Process for Data Mining (CRISP-DM) developed 1996, data mining project consists of six phases (figure 3-1): research understanding phase, data understanding phase, data preparation phase, modelling phase, evaluation phase and deployment phase. The phases are adaptive meaning that next phase often depends on the outcomes of the previous phase (Larose, 2005).

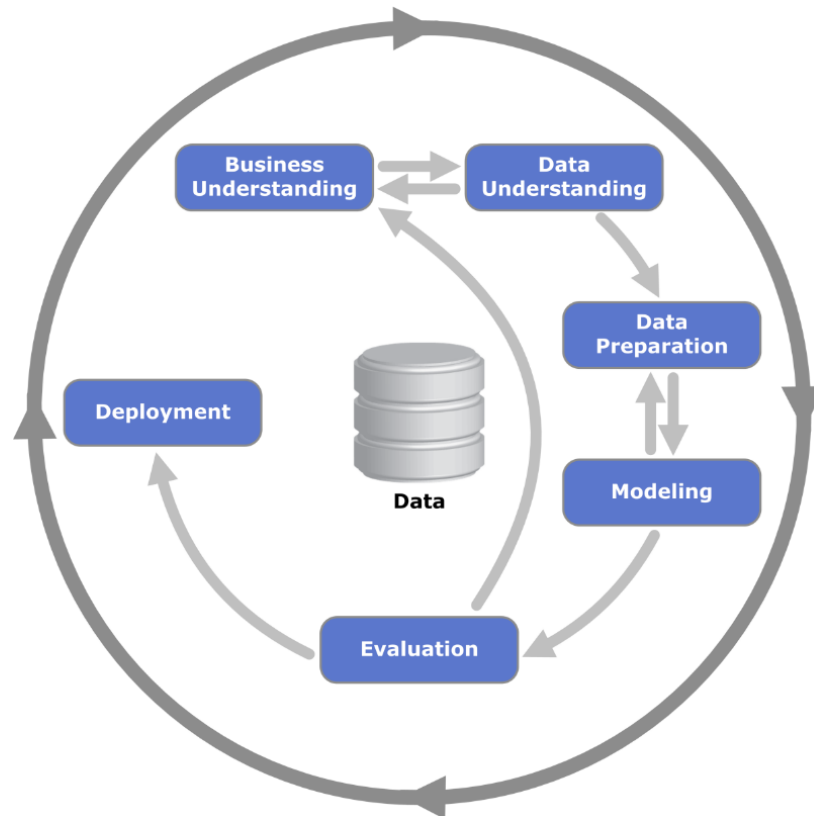

Figure 3-1. Data mining phases according to CRISP-DM (<https://itsalocke.com/blog/crisp-dm-and-why-you-should-know-about-it/>)

### 3.1.1. Research understanding phase

In research understanding phase, the goals and objectives of the project have to be clearly defined. Afterward the requirements and restrictions stated need to be translated into the form of data mining problem definition. The strategy to reach these goals is defined.

### 3.1.2. Data understanding phase

This phase refers to data acquisition and then data analysis to get familiar with the data set and recognize first relationship patterns. It is also necessary to evaluate data quality and already select data set that maybe contains a pattern.

### 3.1.3. Data preparation phase

The raw data are processed, and the final data set is prepared. The variables are chosen and if needed certain transformations are applied. The data are cleaned and prepared for the modelling tool.

#### 3.1.4. Modelling phase

In this phase modelling tools and techniques are selected. Same data mining problem may require various tools. Sometimes it will be necessary to go back to the data preparation phase to adjust data form to meet the requirements of a certain tool.

#### 3.1.5. Evaluation phase

This phase refers to quality check and effectiveness evaluation of the models made in the modelling phase before they are used in the field. The model has to achieve the objectives set in the first phase. In addition, it is necessary to recognize if maybe some research problems have not been sufficiently analysed. In the end, the use of data mining results is discussed.

#### 3.1.6. Deployment phase

The final phase refers to the actual use of the model. For example, a simple deployment report will be generated. In more complex deployment we can implement data mining process in other departments.

#### 4. NEURAL NETWORK

As artificial intelligence (AI) is getting more popular, several new terms are introduced such as machine learning (ML), deep learning (DL) and neural networks (NN). Machine learning can be defined as:

- According to Mitchell, T.M.: Machine learning is a branch of artificial intelligence and “it is the study of computer algorithms to automatically improve through experience.” ;
- According to Samuel A. in 1959: “Machine learning is a large subfield of AI dealing with the field of study that gives computers the ability to learn without being explicitly programmed.”

Deep learning is a subset of machine learning and has many hidden layers even hundreds. Deep learning is inspired by pattern identification and information classification as in the human brain. DL is able to automatically find features and patterns necessary for classification while ML requires manually selected features.

Finally, neural networks are a type of machine learning algorithms that are trying to emulate the human brain. According to Dr. Robert Hecht-Nielsen the neural network (NN) is defined as: “A computing system made up of a number of simple, highly interconnected processing elements, which process information by their dynamic state response to external inputs.” Its development is motivated by the human brain and numerous nerve cells that have ability to work in parallel and ability to learn. Unlike regular programming in which algorithm is explicitly defined, NN is adaptable and learning from training samples. It has ability to associate, learn and is resistant to errors and outliers. It finds application in case of highly nonlinear relationships between data. According to Kriesel, 2005, the main characteristics that NN wants to adapt from human brain principle of working are:

- self-organization and learning capability,
- generalization capability,
- fault-tolerance.

#### 4.1. Architecture of neural network

A neural network consists of input data, hidden layers and output data (figure 4-1). The processing units of each network are artificial neurons usually arranged in layers and corresponding weights which are the connection strengths between two neurons. The information is always propagating layer by layer in the same direction. The neuron collects information from the preceding neuron and propagates the output information to neuron in the following layer. Hidden layers are layers between the first layer – input and the last layer in the network – output. There can be multiple hidden layers and in this part of the neural network the computation is done.

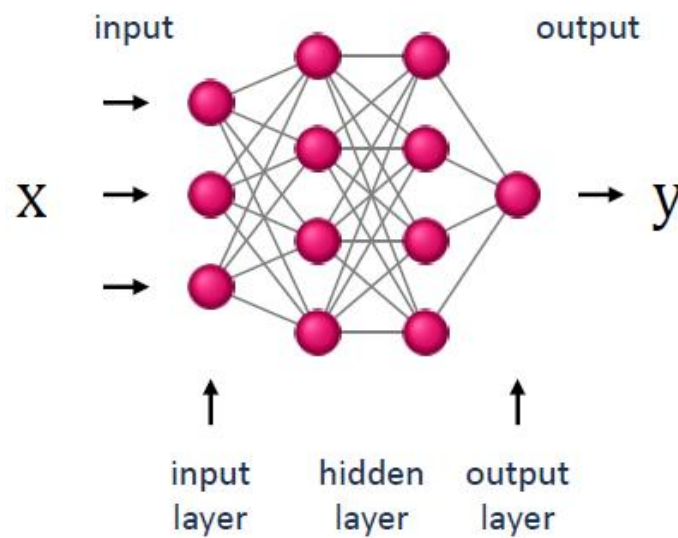

Figure 4-1. Architecture of neural network (Fruhworth, 2018)

Basic components of a neuron are:

- weights,
- bias correction,
- propagation function,
- activation function.

Simplified, three main things happen in the neuron (figure 4-2):

1. First, each input is multiplied by its weight:

$$(x_1 \times w_1; x_2 \times w_2; x_3 \times w_3)$$



2. Next, the weighted inputs are summed up and bias is added:

$$((x_1 \times w_1) + (x_2 \times w_2) + (x_3 \times w_3) + b)$$

3. Finally, the sum is passed through an activation function:

$$y = f(x_1 \times w_1 + x_2 \times w_2 + x_3 \times w_3 + b)$$

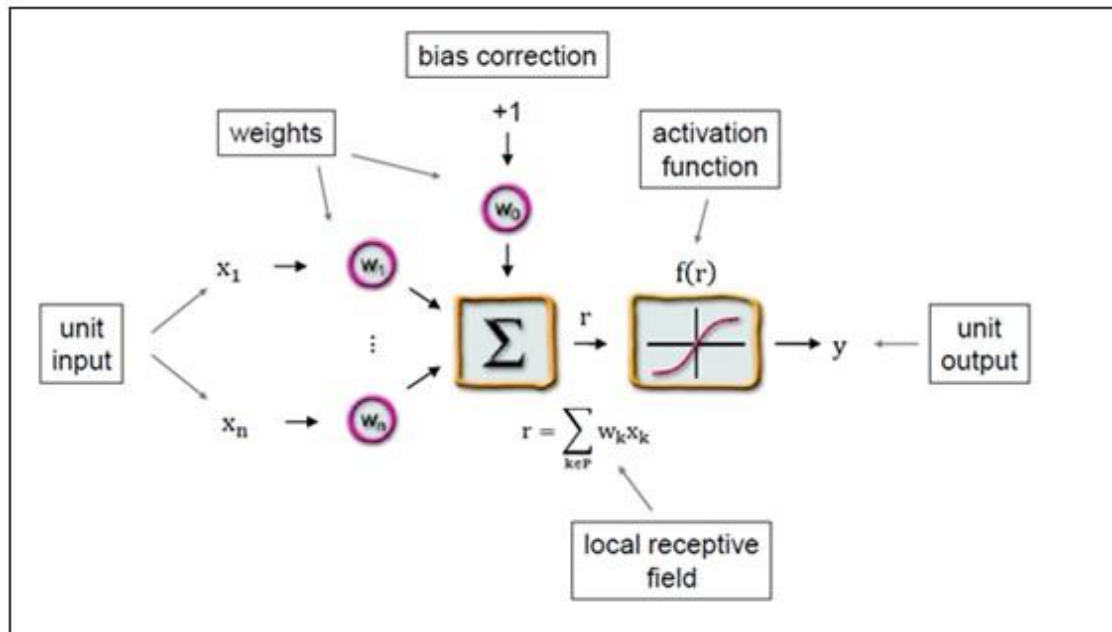

Figure 4-2. Scheme of the artificial neuron and its components (Fruhirth, 2018)

#### 4.1.1. Weights

Neuron usually receives a lot of input data at the same time. Every input has its weight. Weights define the intensity of an input signal. They are measure of input connection strength and can adapt to various training and learning rules. The weights can be excitatory (positive weight) or inhibitory (negative weight) and they are responsible for learning (Kriesel, 2005).

#### 4.1.2. Propagation function

Propagation function receives the output of preceding neuron and transforms it into network input by connecting weights to it. The most common is the summation function which is equal to the sum of all input data multiplied by corresponding weights and then bias

is added. The input data is represented as  $(x_1, x_2, \dots, x_n)$  and weights as  $(w_1, w_2, \dots, w_n)$  so the sum is  $\sum x_n \times w_n$  (Kriesel, 2005).

#### 4.1.3. Bias function

The bias is added to the summation function allowing the unit to shift its nonlinear function horizontally, to the left or right (figure 4-3 and 4-4). If bias neuron was not applied, the function will look like grey function in Figure 4-4. Bias neuron correction affects the function to be shifted to the right –purple function in the figure. The purpose of bias is to better fit the data and it only affects the output values with no interaction with input data. Biases can be positive or negative and when they differ from weights, it means they are independent of previous layer output. Initially, bias is caused by input with the activation value of 1. Afterward by the subtraction of the product of delta value and learning rate, the bias function is updated (Kriesel, 2005).

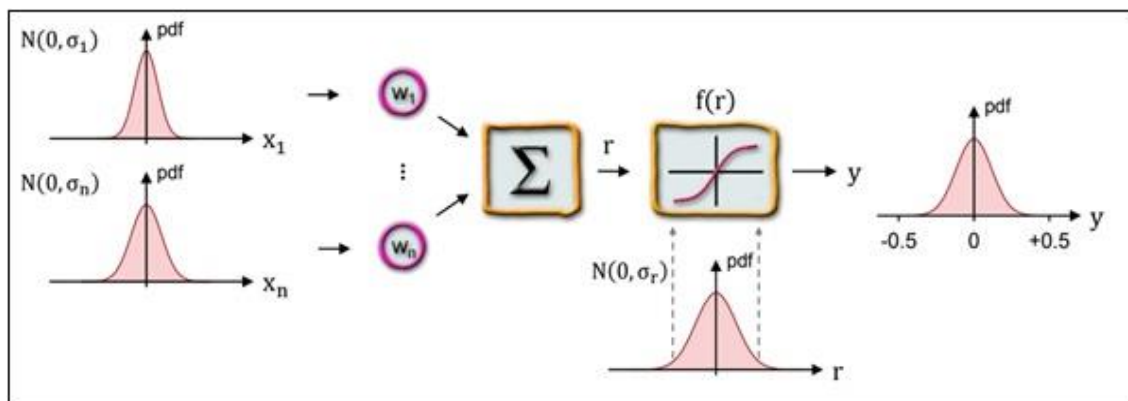

Figure 4-3. Appropriate input in the neural network; no bias added (Fruhirth, 2018)

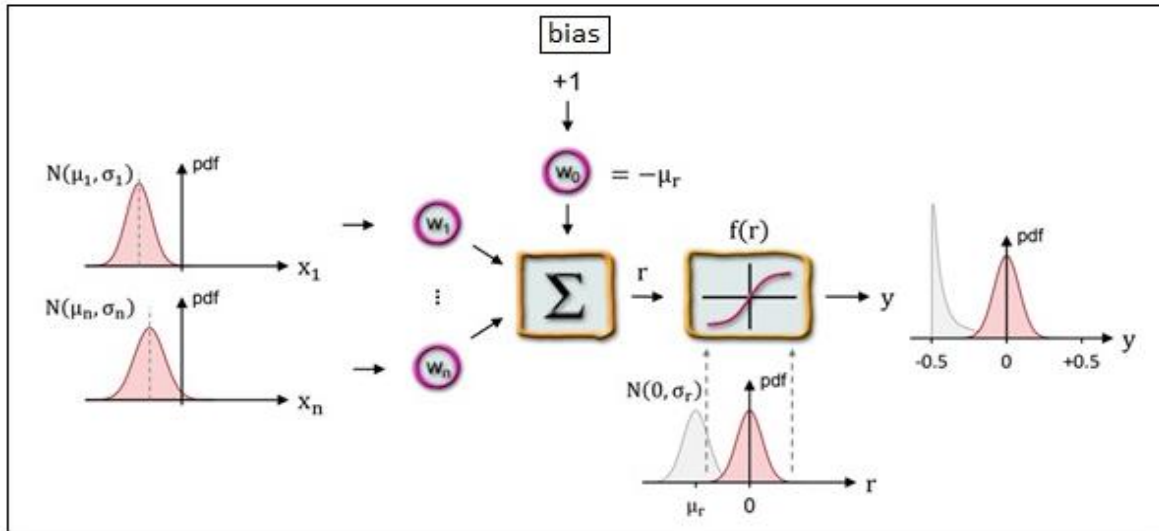

Figure 4-4. Inappropriate input corrected by bias neuron (Fruhirth, 2018)

#### 4.1.4. Activation function

The activation function defines the output of the neuron given input or inputs. It is very sensitive near the threshold value. The threshold value represents the maximum gradient of the activation function. Therefore, the activation function will activate neuron depending on input and threshold value. Unlike other functions and variables in the neural network, the activation function is defined universally for a set of neurons or all neurons in the network. On the other hand, the threshold values are different and changeable. Each neuron has its particular threshold value which can be changed in the learning process. Most common activation functions are (Kriesel, 2005):

- Sigmoid function takes real values of input data and puts it in the range  $[0,1]$

$$\sigma(x) = 1/(1 + e^{-x})$$

- Tanh function takes real values of input data and puts it in the range  $[-1,1]$

$$\tanh(x) = 2\sigma(2x) - 1$$

- ReLU function (Rectified Linear Unit) takes real values of input data and thresholds it at zero meaning negative values are replaced by zero

$$f(x) = \max(0, x)$$

## 4.2. Fundamental principles of learning and training the neural network

As mentioned before, one of the most interesting characteristics of neural networks is their capability to learn, get familiar with the problem and after training be able to solve problems of the same class. There are several ways of how neural network can learn. According to Kriesel, 2005, the learning can be achieved by:

- developing new connections or deleting the existing connection,
- changing weights,
- changing the threshold value,
- varying some of the three functions (propagation, activation or output function),
- developing new neurons or deleting existing neurons.

The most common way of learning is by changing the weights. Learning process is accomplished by algorithm implementation. There are three different learning types (Kriesel, 2005):

- **Supervised learning.** In the supervised learning, the training set is composed of input data and output data as a response to the input. This way, the output of each training set in the network is compared to solutions and weights are adjusted according to the difference between the correct solution and output. The goal is to have a network that will adjust weights that can provide solutions for new and unknown data and be able to generalize and make reasonable predictions.
- **Unsupervised learning.** This type of learning is used when there is a large amount of data and the user does not understand the context of data. The algorithms seek patterns in data and segregated data into groups of features. A training set has only the input patterns and based on it, the algorithm tries to generate pattern classes and classify them into categories.
- **Reinforcement learning.** Type of learning based on a trial and error approach. The algorithm gets feedback after analysing the data and the user is guided to the best fit result. The training set contains the input patterns and after each sequence, the network receives a value defining the result and is it wrong or right.

#### 4.2.1. Challenges in training a neural network model

There are two types of effect that can happen during training of neural network (Panchal & Panchal, 2014):

- Overfitting. It can happen when more neurons than necessary are present in the network.
- Underfitting. It can happen when there are not enough neurons in the network compared to complexity of the data.

By increasing the number of neurons, the network is able to solve more complex problems. However, if the number of neurons is set too high it can lead to overfitting. That means the neural network model is very close to the training set which makes generalization difficult and the model is not able to make valid predictions. It is very difficult to detect if overfitting is occurring. Only by new data coming into the model, we can be sure if the model is working properly. The same is for underfitting effect. By training the network too much, so called overtraining, the network will overfit the training data set resulting in bad performance on the test set. The solution is to stop the training when performance on the validation set starts to decrease. This is usually called early stopping (<https://machinelearningmastery.com/early-stopping-to-avoid-overtraining-neural-network-models/>).

Generally, a good practice is to split the dataset into three parts: training set, validation set, and test set. The neural network model learns only on the training set. The validation set keeps track about the progress and considers the optimization of the model. Finally, the test set is used as a performance evaluation. The percentage of split data can be tailored to each neural network. However, usually, data is split into 70% for training, 15% for validation and 15% for testing.

#### 4.3. Types of neural network

Artificial neurons in the network can be connected in several different ways forming specific architectures. The oldest and simplest model of the neuron is perceptron (<https://towardsdatascience.com/the-mostly-complete-chart-of-neural-networks-explained-3fb6f2367464>). It sums up the input, applies activation function and transfers further to the

output layer. The scheme is shown in figure 4-5. However, there are many different, more complicated classifications of neural networks.

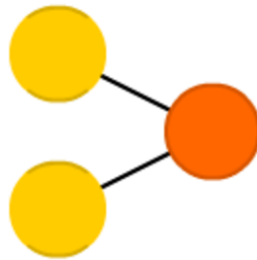

Figure 4-5. Perceptron- the simplest model of neural network

(<https://towardsdatascience.com/the-mostly-complete-chart-of-neural-networks-explained-3fb6f2367464>)

#### 4.3.1. Feedforward network

Feedforward network is a type of neural network in which data propagates in only one direction. The data is passing through different neurons until it reaches the output layer with no backpropagation. Feedforward networks are able to deal with a lot of noise data and are usually used in technologies such as face recognition.

- Single-layer feedforward network. The simplest neural network is a single layer feedforward network (figure 4-6). In this network, the input layer is directly connected to the output layer. The term single layer refers only to the output layer because the input layer does not perform any computation on input data, so it is not considered (Beckenkamp, 2002; Kriesel, 2005).

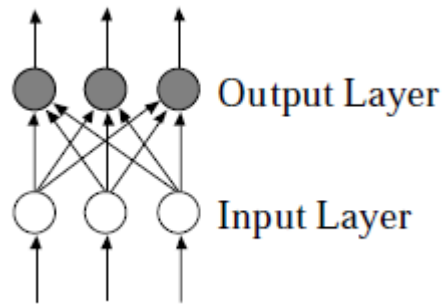

Figure 4-6. Single-layer feedforward network (Beckenkamp, 2002)

- Multi-layer feedforward network. In this network one or more hidden layer are added, more connections and neural iterations are present, thus it can deal with more complicated problems. We can differ fully connected multi-layer feedforward network (figure 4-7) and not fully connected (figure 4-8). In the fully connected each neuron in one layer is connected to all neurons from another layer. In case of not fully connected, the user has information about the pattern and its classification and is able to remove invalid or unnecessary connections. This type of network can also be called a deep network when it has many hidden layers (Beckenkamp, 2002; Kriesel, 2005).

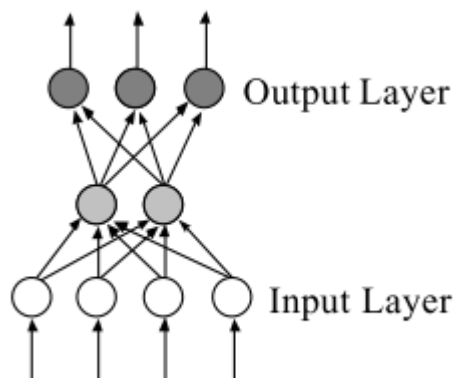

Figure 4-7. Multi-layer feedforward network fully connected (Beckenkamp, 2002)

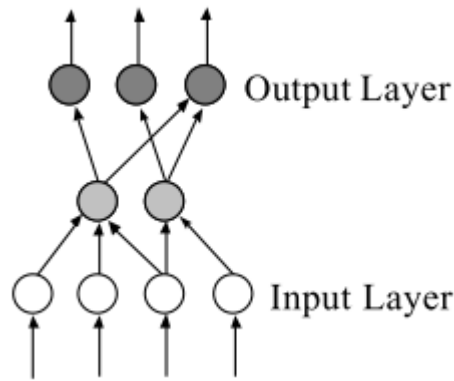

Figure 4-8. Multi-layer feedforward network not fully connected (Beckenkamp, 2002)

#### 4.3.2. Recurrent neural networks (RNN)

The recurrent neural network (figure 4-9) has a feedback loop. The feedback can be from the output of one neuron to the input of another which is called indirect recurrence. It can happen between neurons in the same layer or between neurons of different layers. Another option is also a self-feedback or direct recurrence meaning the output of the neuron is returned to its input, so the neuron is connected to itself. Lateral recurrences refer to the connections of neurons within the same layer. The feedback enhances learning capability of the neural network making its performance better (Beckenkamp, 2002; Kriesel, 2005).

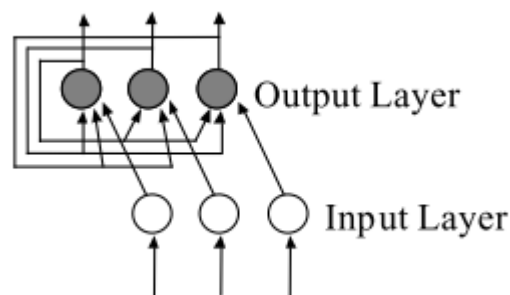

Figure 4-9. Recurrent network with no self-feedback loops (Beckenkamp, 2002)



### 4.3.3. Lattice network

Lattice network is formed of arrays of neurons. Input neuron is connected to the arrays transferring the signal to them. In figure 4-10 the architecture of the lattice network is shown. This network has three by three neurons and each fed from three input neurons (Beckenkamp, 2002).

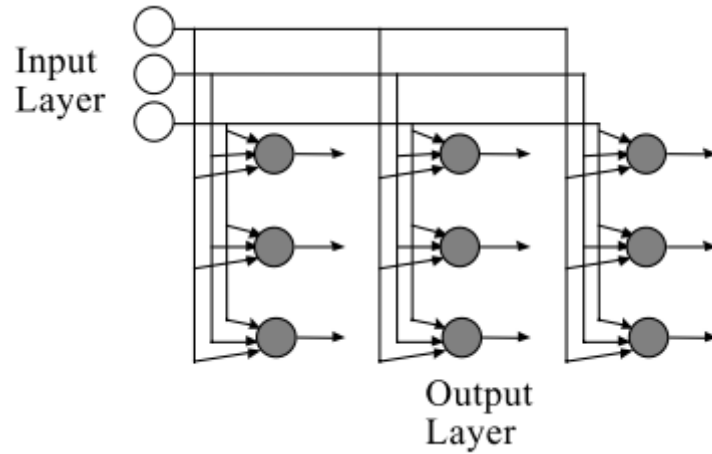

Figure 4-10. Lattice network (Beckenkamp, 2002)

## 5. ANALYSIS OF A GAS WELL IN CROATIA

The exploitation of gas in Well X started in 2006 and till now it produces gas naturally without artificial lift system. It produces from sandstone reservoirs and gas composition is 99,37% of methane with 0,15% of CO<sub>2</sub> and 0,48% of N<sub>2</sub>. Reservoir intervals in this well have very low or no compaction at all. The primary porosity is around 30% while permeability is around 100 mD. However, the low compaction in this well results in sand production problems and decline in reservoir pressure. In order to deal with problems with sand, depending on petrophysical characteristics of reservoir, frack&pack (FP) or high rate water pack technique (HRWP) is used. In frack&pack technique, small parts of reservoir are fractured under high pressure. It is used in low permeability reservoirs when there is no danger of water breakthrough from other adjacent reservoirs after fracturing. High rate water pack technique is when gravel pack is set in the well where screen is placed. It is set at or near the fracturing pressure of the reservoir.

There are 8 reservoir intervals perforated in well X: A1, A5, A5a, A5h, A6, A6a, A8, and A12. As it can be seen in figure 5-1 in 2006 all intervals were opened and producing. In 2012, interval A1 was closed while intervals A6 and A12 were closed in 2013. Increased water production resulted in closing these three intervals.

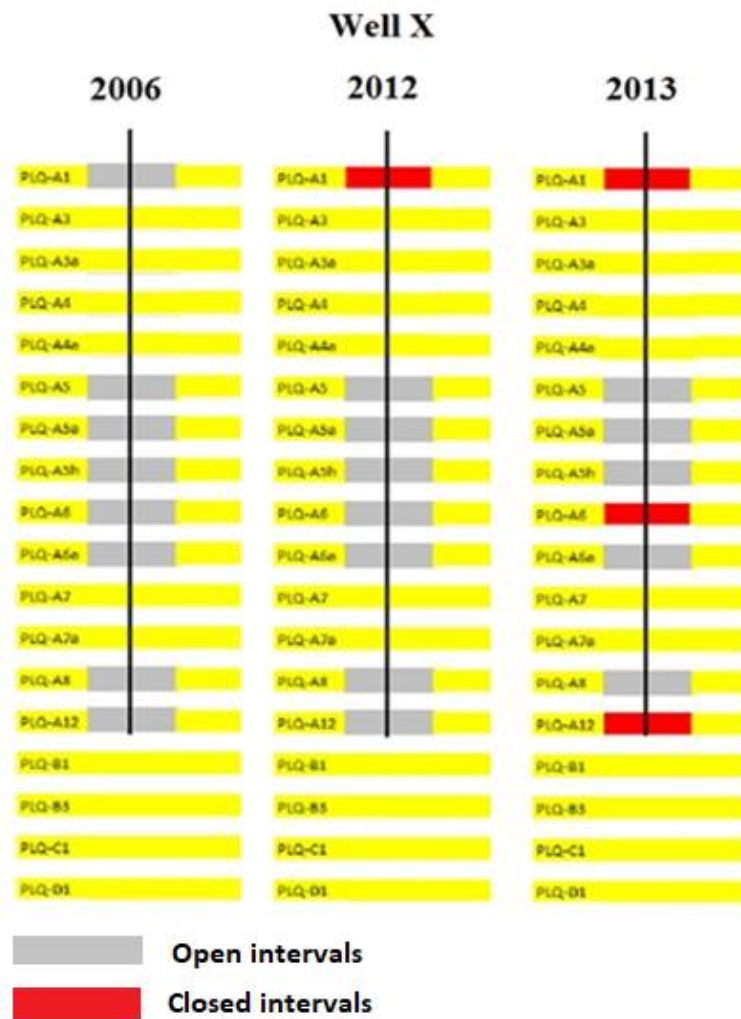

Figure 5-1. Open and closed intervals in well X

### 5.1. Production characteristics of well X

Based on the data from the company, production trend and characteristics are determined. Parameters that are investigated are gas rate, water rate, and wellhead pressure. Based on the trends of these parameters, significant changes in the lifetime of the well can be determined. It is shown in figure 5-2 that important problem in this well is water. In figure 5-2, orange line represents gas production with corresponding values at left y-axes. The blue line represents water production with corresponding values at right y-axes and black line is wellhead pressure with corresponding values at right y-axes. Water production was held at minimum until 2011 when it increased significantly. That was the reason why it was decided

to close intervals. First, interval A1 was closed in 2012. Afterward, intervals A6 and A12 were closed in 2013.

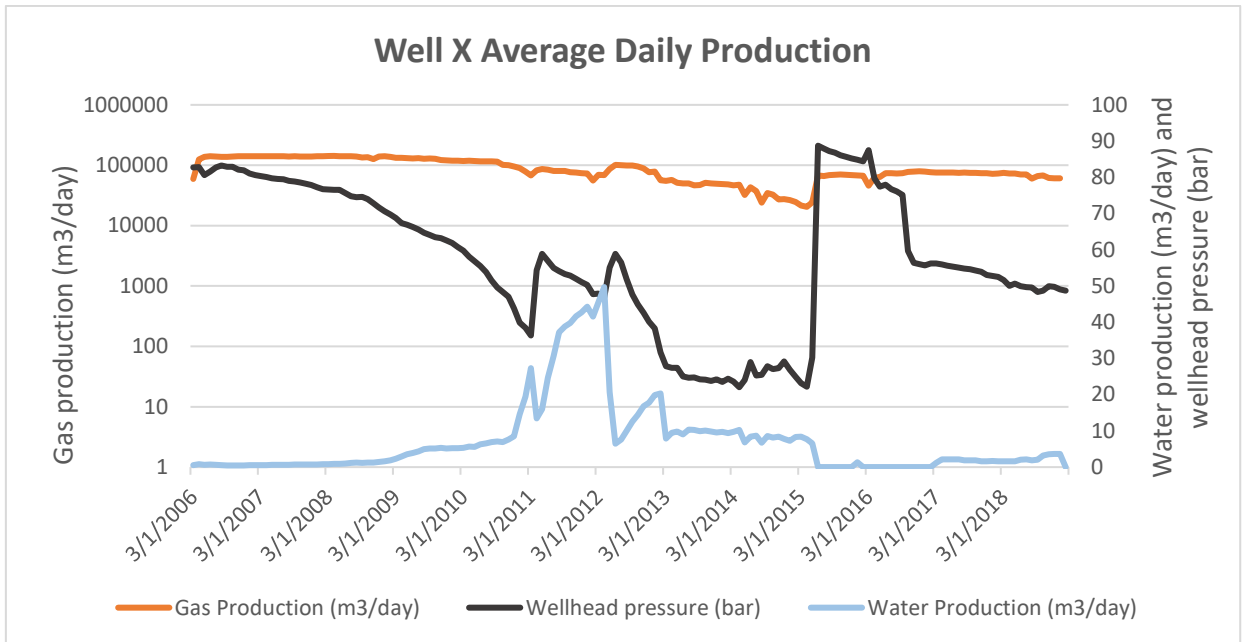

Figure 5-2. Production characteristics of Well X

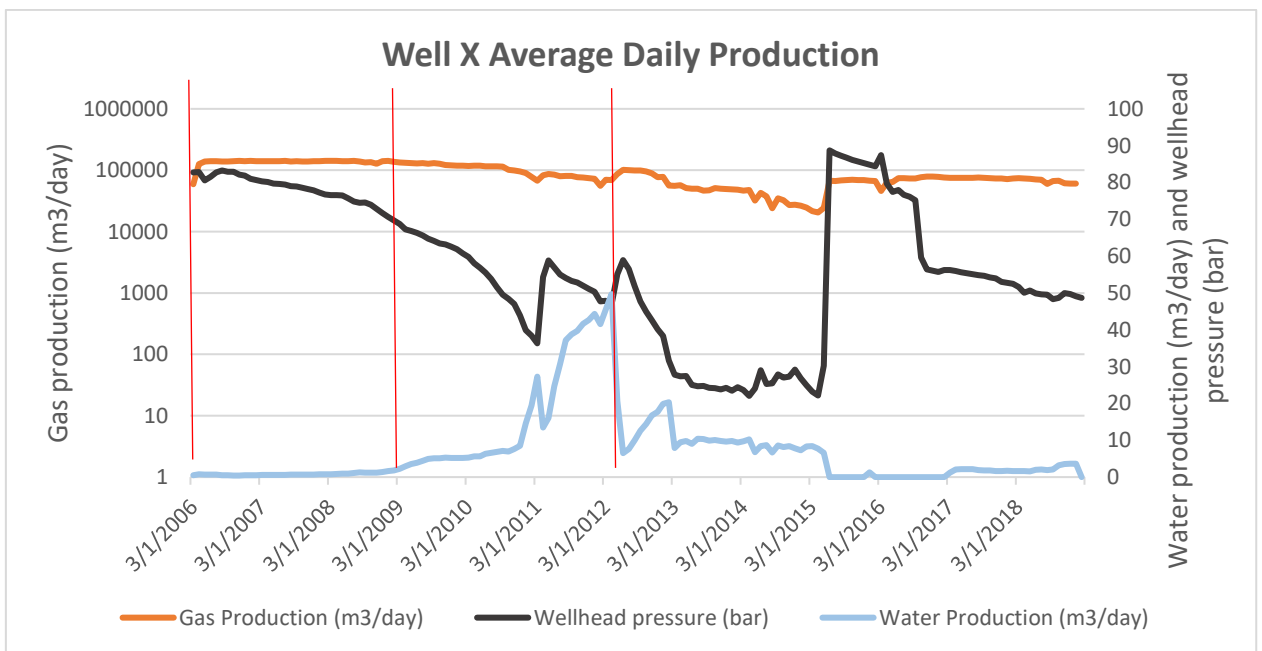

Figure 5-3. Production characteristics of Well X and time intervals (red line) for which analysis was performed

Fluid production is observed in three specific periods (red lines in figure 5-3)– at the beginning in 2006, in 2009 when water production and wellhead pressure started to change

and finally in 2012 when water production was at the highest rate and just before A1 interval was closed.

In order to make best decision where to implement ICVs in well X and how to obtain results which will give information about possible production improvements if intelligent equipment is used, it was necessary to look into various set of data. Data that is necessary for the analysis is: completion design (casing design, downhole equipment, perforation details), reservoir data (reservoir temperature and pressure for each perforated interval, permeabilities, skin), well tests, workover programs, well logs. However, it was not possible to gather all specific data. Therefore, model was built in PIPESIM with available data and other input data was inserted until the model matched production data provided by company.

## **5.2. Building a physical model in commercial software PIPESIM**

One of the objectives of this thesis is to consider the possibility of intelligent completion implementation and simulate production if ICVs were used and intervals were not closed. Finally, the goal is to build neural network which will manage ICV opening depending on production rates and bottomhole pressure. A model was made in software PIPESIM to simulate cases for different ICV sizes (2-15 mm) and find the optimal ones. For each of these three intervals that were closed (A1, A6, and A12) due to high water production, downhole choke is selected. However, before simulating ICV impact on intervals of interest, basic model was built with conventional completion.

### **5.2.1. Original model**

For building a basic model of well X in PIPESIM, workflow shown in figure 5-4 was used.

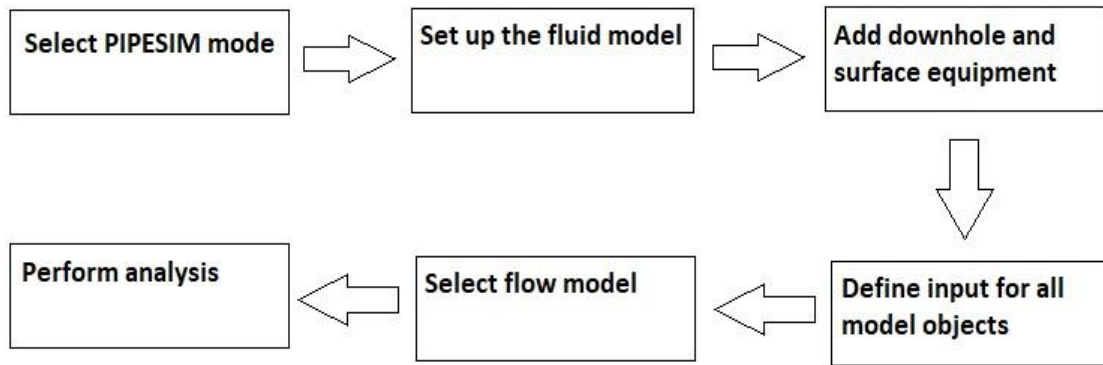

Figure 5-4. PIPESIM workflow

Steps to build a wellbore physical model include:

1. Selection of an appropriate model, either single well or multiple wells.

In this case, the chosen model is single well.

2. Set up the fluid model.

PIPESIM offers the possibility to choose between the black oil model and compositional model. The selected model is black oil model and as production fluid is gas, oil-gas ratio (OGR) equals zero. As there are several intervals producing in well X and high water production comes from A1, A6 and A12, different fluids are used for simulation. For intervals A5, A5a, A5h, A6a and A8 fluid BOfluid (figure 5-5) is used with water-gas ratio (WGR) close to zero (as those intervals are currently not producing high amount of water). For the interval A1, fluid A1 is used with corresponding water ratio and for the intervals A6 and A12, another fluid – A6 and A12 fluid with corresponding water ratio is used.

	Fluid	Gas ratio type	Gas ratio	Gas ratio unit	Water ratio type	Water ratio	Water ratio unit	Description
1	A1	OGR	0	sm <sup>3</sup> /mms...	WGR	44	sm <sup>3</sup> /mms...	
2	A6 and A12	OGR	0	sm <sup>3</sup> /mms...	WGR	0.42	sm <sup>3</sup> /mms...	
3	BOfluid	OGR	0	sm <sup>3</sup> /mms...	WGR	0.001	sm <sup>3</sup> /mms...	
	+							

Figure 5-5. Fluid characteristics for interval A1, A6 and A12, and BOfluid that represents fluid produced from other intervals

3. Add downhole and surface equipment.

Casing sizes and depths are shown in Table 5-1. Scheme of well completion is shown in figure 5-6 and surface equipment which includes wellhead, choke, sink and flowlines in figure 5-7.

Table 5-1. Casing design for well X

<b>Equipment</b>	<b>Name</b>	<b>Depth (m)</b>	<b>OD (mm)</b>	<b>ID (mm)</b>	<b>Wall thickness (mm)</b>	<b>Roughness (mm)</b>
Casing	Conductor	130.0	508,0	457.2	25.4	0.0254
Casing	Surface Casing	306.0	339,7	317.9	10.9	0.0254
Casing	Intermediate Casing	1298.0	244,5	224.4	10.0	0.0254
Casing	Production Casing	2442.0	177,8	159.4	9.2	0.0254
Tubing	Tubing	2074.0	73,0	62.0	5.5	0.0254

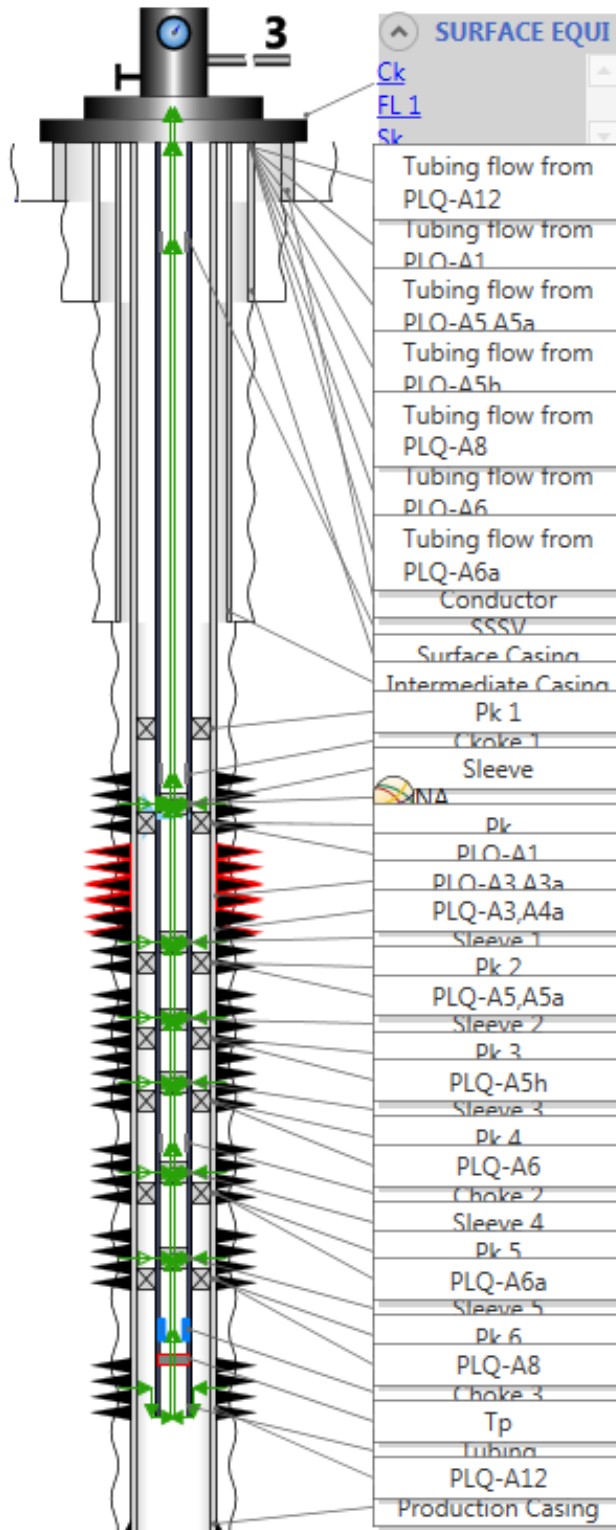

Figure 5-6. Well X completion scheme, simulated in PIPESIM



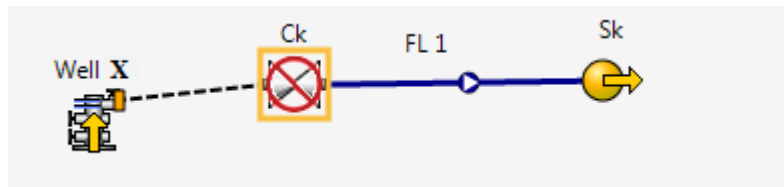

Figure 5-7. Surface equipment of Well X

Where Ck is surface choke (currently not in use), FL 1 is flowline and Sk is sink (end of the system).

4. Define basic data for each model object.

In this step wellbore geometry is specified (deviated well). Reservoir intervals were defined (perforation depths) and data such as well test data, reservoir pressure, reservoir temperature were defined. Example of well test data table is shown in figure 5-8.

**Survey data**

Name: Well X

Type:  Well  Flowline

Date/Time: 7/29/2019 1:51 PM

Oil flowrate: 0 sm<sup>3</sup>/d

Water flowrate: 0.7 sm<sup>3</sup>/d

Gas flowrate: 0.14 mmsm<sup>3</sup>/d

GOR: Infinity sm<sup>3</sup>/sm<sup>3</sup>

Watercut: 100 %

**COMMENTS**

Survey comments:

**PROFILE DATA**

Fluid phases:  2-phase  3-phase

	Measured depth	Pressure	Temperature	Liquid holdup	Gas holdup
	m	bara	degC	%	%
1	0	81.29			
2	300	84.23			
3	600	85.94			
4	900	88.34			
5	1200	90.07			
6	1500	91.94			
7	1600	92.56			
8	1700	93.25			
9	1709	93.35			
10	1730	93.55			
11	1760	93.72			
12	1780	93.98			
13	1793	94.02			
14	1820	94.15			
15	1860	94.29			
16	1870	94.44			
17	1890	94.53			
18	1900	94.59			
19	1950	94.85			
20	2000	95.11			
21	2050	95.48			
22	2075	95.77			
+					

Figure 5-8. Well test data

- Select flow model for simulation of individual components in the system.  
 For each interval, “Jones” equation is used for calculating inflow performance relationship (IPR). For the calculation of vertical lift performance (VLP), in horizontal section of the well selected correlations are “Beggs and Brill original” and “Baker Jardine Revised”. For vertical section flow, “Grey modified”, “Grey original” and “Hagedorn Brown” were selected. After choosing correlations, it is necessary to perform data matching to make sure selected equation fits the data. In figure 5-9 it is shown which correlations are available for calculations and which one are selected. In figure 5-10 it is shown that correlations fit the data which means, for each selected

correlation, the calculated data falls on the line that represents the real data. That means that each of these correlations can be used for further calculations.

Data matching Profile results Results summary

**GENERAL**  
 Branch start: Well X - Reservoir  
 Branch end: Well X - Wellhead  
 Default profile plot: Pressure vs. total distance  
 Well survey data: Well X 7/29/2019 1:51:18 PM  
 Override flowrate:

**CALCULATED VARIABLE**  
 Inlet pressure  
 Outlet pressure 81 bara  
 Gas flowrate 0.14 mmsm<sup>3</sup>/d

**FLUID RATIOS**

	Inflow	LGR	Watercut
		sm <sup>3</sup> /mms...	%
1	PLQ-A1	5	0
2	PLQ-A5,A5a	0	0
3	PLQ-A5h	0	0
4	PLQ-A6	2	0

**REGRESSION PARAMETER SETUP**

Regression parameter	Calibrate	Min.	Max.
1 Vertical friction factor	<input checked="" type="checkbox"/>	0.5	2
2 Vertical holdup factor	<input checked="" type="checkbox"/>	0.5	2
3 Horizontal friction factor	<input checked="" type="checkbox"/>	0.5	2
4 Horizontal holdup factor	<input checked="" type="checkbox"/>	0.5	2
5 U Value multiplier	<input checked="" type="checkbox"/>	0.1	10

**RMS WEIGHT FACTORS**  
 Pressure: 1  
 Temperature: 1  
 Liquid holdup: 1

**HEAT TRANSFER OPTIONS**  
 Override heat transfer options:   
 Inside film coefficient method: Kreith

**FLOW CORRELATIONS**  
 Swap angle: 45 deg

Type to filter

Vertical flow (multiphase)	Selected
11 Govier, Aziz [Tulsa (Legacy 1989)]	<input type="checkbox"/>
12 Gray (modified)	<input checked="" type="checkbox"/>
13 Gray (original)	<input checked="" type="checkbox"/>
14 Gregory	<input type="checkbox"/>
15 Hagedorn & Brown	<input checked="" type="checkbox"/>
16 Hagedorn & Brown (Original) [Tuls...	<input type="checkbox"/>
17 Hagedorn & Brown (Revised) [Tuls...	<input type="checkbox"/>
18 Hagedorn & Brown, Duns & Ros m...	<input type="checkbox"/>
19 LedaFlow v. 1.4 2-Phase	<input type="checkbox"/>
20 LedaFlow v. 1.4 3-Phase	<input type="checkbox"/>

Type to filter

Horizontal flow (multiphase)	Selected
1 Baker Jardine Revised	<input checked="" type="checkbox"/>
2 Beggs & Brill [Tulsa (Legacy 1989)]	<input type="checkbox"/>
3 Beggs & Brill Original	<input checked="" type="checkbox"/>
4 Beggs & Brill Revised	<input type="checkbox"/>
5 Beggs & Brill Revised, Taitel Dukler...	<input type="checkbox"/>
6 Beggs & Brill, Taitel Dukler map	<input type="checkbox"/>
7 Dukler [Tulsa (Legacy 1989)]	<input type="checkbox"/>
8 Dukler, AGA & Flanigan	<input type="checkbox"/>
9 Dukler, AGA & Flanigan (Eaton Hol...	<input type="checkbox"/>
10 Eaton Oliemans	<input type="checkbox"/>

Figure 5-9. Correlations used for calculation of IPR and VLP

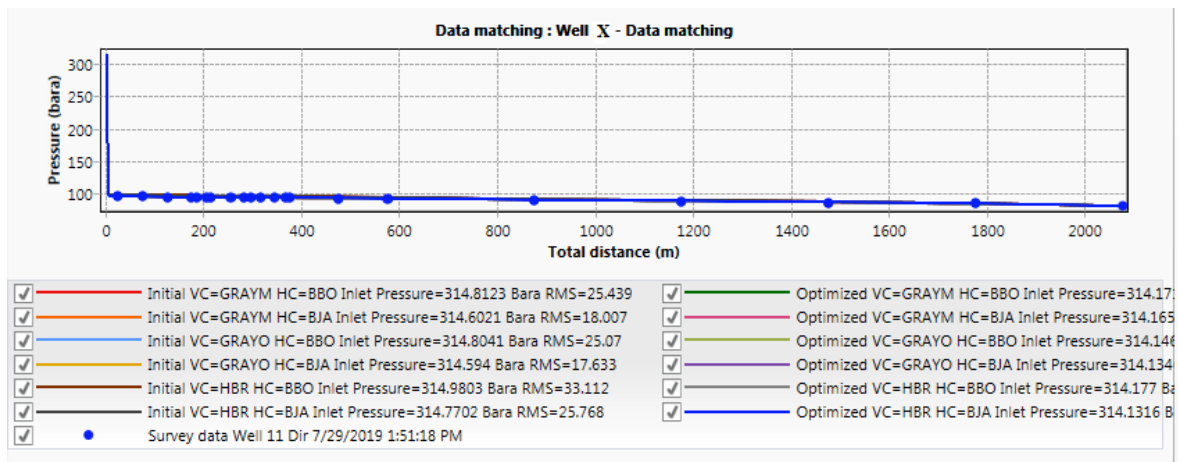

Figure 5-10. Data matching

6. Perform an operation such as P/T profile, nodal analysis and system analysis.

In this step, analysis of the system can be performed, and various variables can be analysed. In figure 5-11 the IPR and VLP curves and operating point of the system are shown.

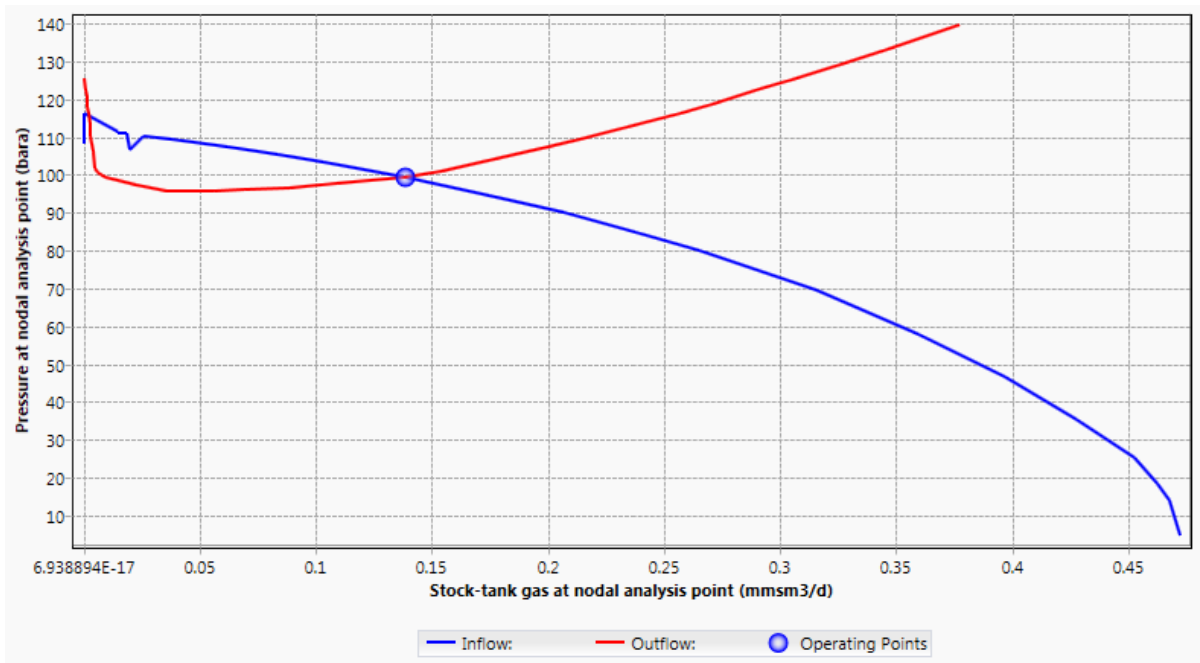

Figure 5-11. IPR and VLP curves

### 5.2.2. Customized PIPESIM model

Customized PIPESIM model was made in order to perform simulations with implemented ICVs. Three ICVs with other necessary equipment are installed at depths that correspond to closed intervals A1, A6 and A12 (table 5-2). In table 5-2 the ICVs are labelled as chokes because PIPESIM only offers possibility to install regular downhole chokes not intelligent equipment. Simulations are performed for ICV sizes from 2 to 15 mm (figure 5-12, 5-13, 5-14). After simulations three sizes for each interval are selected. The selection was based on significant changes seen in production and for ICVs that show similar results, one size was selected. Choke size selected are 4, 6 and 8 mm for each interval.

Table 5-2. List of installed equipment for customized PIPESIM model

<b>Equipment</b>	<b>Name</b>	<b>Depth (m)</b>
SSSV	SSSV	176.2
Packer	Pk 1	1674.0
Choke	Choke 1	1701.0
Sliding sleeve	Sleeve	1703.0
Packer	Pk	1705.0
Sliding sleeve	Sleeve 1	1795.5
Packer	Pk 2	1800.0
Sliding sleeve	Sleeve 2	1868.5
Packer	Pk 3	1875.0
Sliding sleeve	Sleeve 3	1887.5
Packer	Pk 4	1895.0
Choke	Choke 2	1901.0
Sliding sleeve	Sleeve 4	1902.5
Packer	Pk 5	1910.0
Sliding sleeve	Sleeve 5	2020.0
Packer	Pk 6	2028.0
Choke	Choke 3	2072.0
Tubing plug	Tp	2073.0

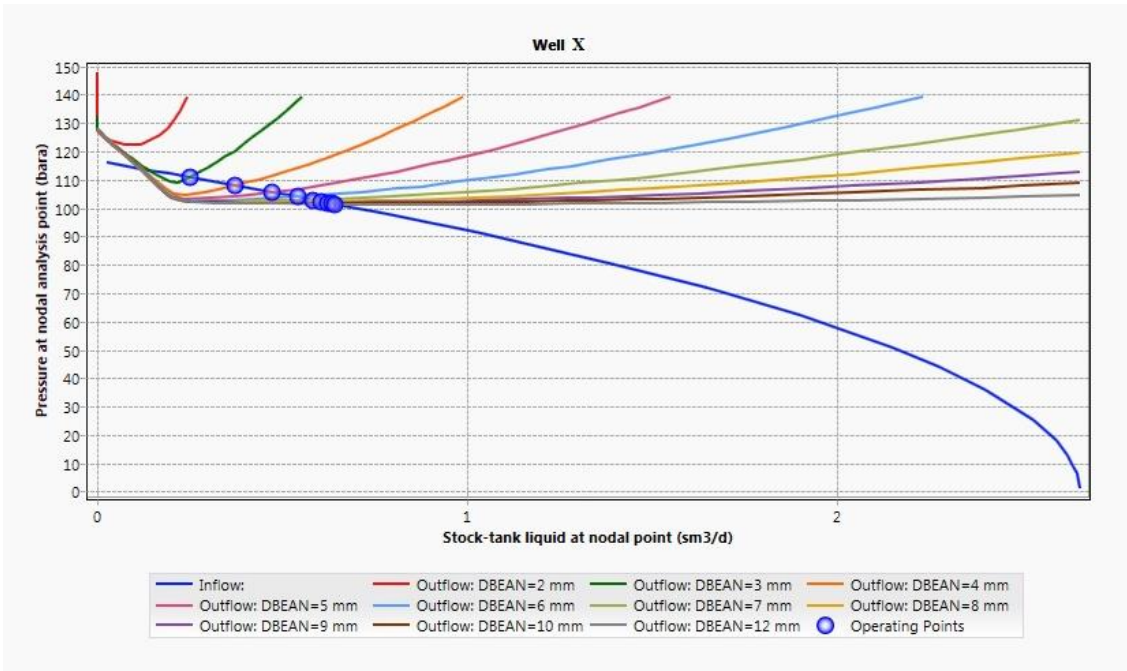

Figure 5-12. Different choke size performance for interval A1

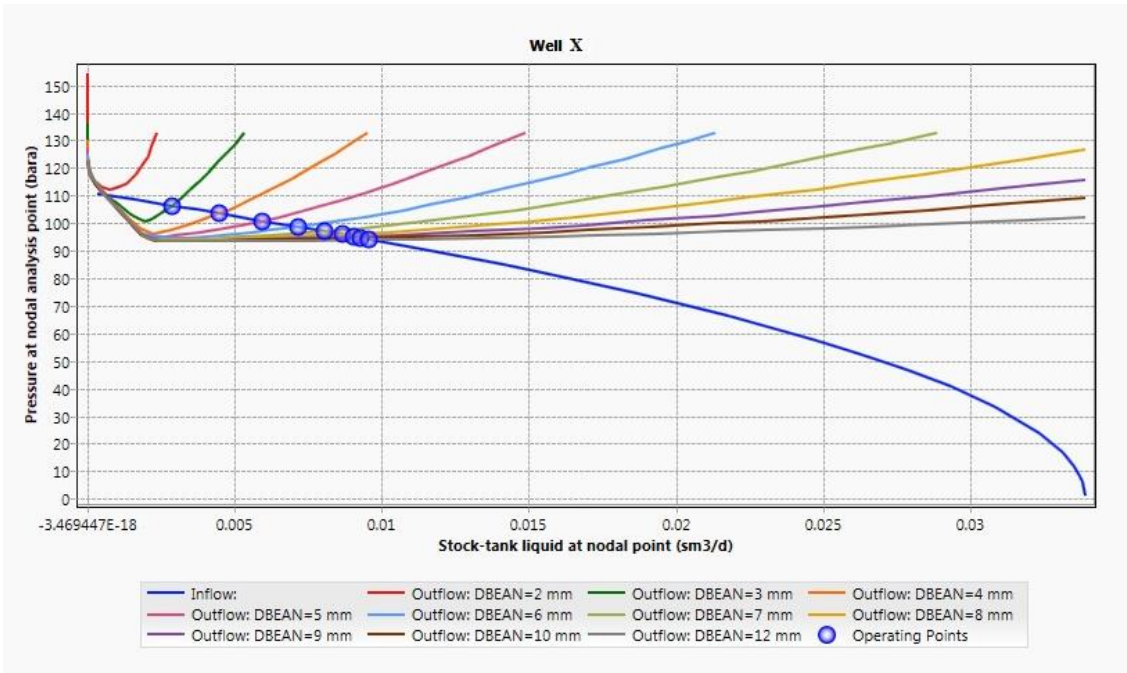

Figure 5-13. Different choke size performance for interval A6

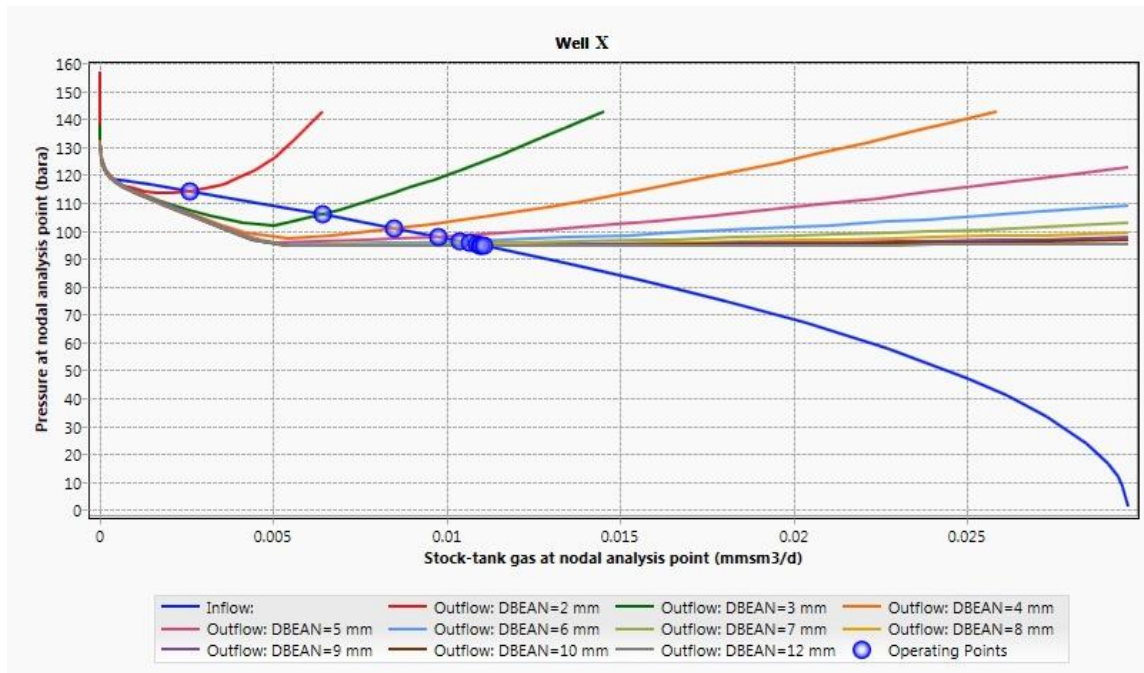

Figure 5-14. Different choke size performance for interval A12

As intelligent completion is considered and at the moment is not implemented, there are no downhole sensors and therefore there is no real-time data about bottomhole pressures. In order to build neural network as a final step of this thesis, it was necessary to generate bottomhole flowing pressures. The data was obtained from the software once the customized model was built and choke size were selected.

#### 5.2.2.1. Choke model

As one of the main ideas is to investigate how ICVs will affect production characteristics if they are installed, after basic PIPESIM model was made, downhole chokes were added to the model to simulate different cases. PIPESIM has no option to install intelligent completion, particularly ICVs or ICDs so regular chokes with different choke bean sizes were used for simulations. Mokhtari and Waltrich, 2016 investigated how to simulate multiphase flow models in PIPESIM and which equations best describe certain components and among others, the choke was investigated. According to them, choke model in PIPESIM is described the best by Mechanistic and API-14B model.

In the choke valve, as the pressure difference increases, fluid velocity will also increase and if the compressible fluid is present it reaches sonic velocity. When the sonic

velocity is reached, the fluid flow becomes critical and independent of downstream pressure. In the software, there are nine correlations available for critical flow and three for subcritical. As the mechanistic and API-14B model showed to be the best according to literature, it was used in the simulation for well X and is described here.

The basic equation that all correlations use is:

$$q_l = \frac{p_{up} 64 d^C}{AGLR^B} \quad (1)$$

Where:

$q_l$  – liquid flow rate (m<sup>3</sup>/s)

$p_{up}$  – pressure upstream to choke (bar)

$d$  – choke orifice (mm)

GLR – gas liquid ratio (m<sup>3</sup>/m<sup>3</sup>)

A, B, C – coefficients determined empirical

In choke subcritical flow using Mechanistic and API-14B models, the pressure drop across the choke is (Mokhtari and Waltrich, 2016):

$$\Delta P = \frac{\rho_n \times v^2}{2 \times c} \times \left[ \frac{\lambda_L}{(c_{vL} \times Z_L)^2} + \frac{\lambda_G}{(c_{vG} \times Z_G)^2} \right] \quad (2)$$

Where:

$$\rho_n = \lambda_L \rho_L + \lambda_G \rho_G \quad (3)$$

$$v = \frac{q}{A_{bean} \times \rho_n} \quad (4)$$

$$Z_L = 1 \quad (5)$$

$$Z_G = 1 - \frac{0.41 + 0.35 \delta^4}{\gamma} \times \frac{\Delta P}{P_{up}} \quad (6)$$

The assumptions in this model are fluid flow is incompressible and gas flow is incompressible and adiabatic.

For the choke critical flow using Mechanistic and API-14B models, the same correlations are used like the ones in subcritical flow with the addition:



$$\Delta p = (1 - C_{PR})p_{up} \quad (7)$$

Where:

$A_{bean}$  - choke area ( $m^2$ )

$C_{PR}$  – critical pressure ratio proposed by Ashford-Pierce

$Z_g$  – gas compressibility factor

$Z_l$  – liquid compressibility factor

$q$  - total mixture flowrate ( $m^3/s$ )

$\gamma$  – gas specific gravity

$\Delta P$  – pressure loss across the choke (bar)

$\lambda_g$  – gas flowing fraction

$\lambda_l$  – liquid flowing fraction

$v$  – mixture velocity ( $m^2/s$ )

$\rho_g$  – gas density ( $kg/m^3$ )

$\rho_l$  – liquid density ( $kg/m^3$ )

$\rho_n$  - non-slip mixture density ( $kg/m^3$ )

For the mechanistic and API-14B model, gas discharge coefficient is a constant number  $c_{vg}=0.9$ , as well as liquid discharge coefficient  $c_{vl}=0.85$ .

#### 5.2.2.2. Different cases simulated in PIPESIM

After making a basic model in PIPESIM that matches actual production characteristics of the well and after customized model was built with installed ICVs, next step includes simulation of different cases. As it was mentioned, three reservoir intervals (A1, A6, A12) showed to be problematic due to high water production. The objective of simulations of different cases is to assume several scenarios that are possible to happen in the well. As there is no real-time data from the sensors, four variables were changed as possible scenarios, sensitivity analysis was performed and data necessary for neural network was generated.

Cases that were simulated:

- WGR: 20, 40, 60, 80, 120, 150, 200, 300 and 400 m<sup>3</sup>/mmsm<sup>3</sup>,
- Choke sizes: 4, 6 and 8 mm,
- Outlet pressures: 40, 50, 60, 70 and 80 bar,
- Reservoirs pressure: 95, 100, 105, 110, 115 and 119 bar (choke 1 and choke 3) and 90, 95, 100, 105, 109 bar (choke 2).

Parameters obtained after simulating different cases:

- stock tank liquid rate,
- stock tank gas rate,
- bottomhole pressure,
- temperature difference,
- maximum liquid loading gas rate,
- choke critical pressure ratio,
- choke pressure drop,
- critical choke pressure drop.

After making different scenarios, output data was exported to Excel. For each combination of these variables, data was thoroughly studied. Optimal choke size was selected for each case. The optimal size selection was based on comparison of parameters: water rate, gas rate and bottomhole pressure. The example of choke selection is shown in Chapter 8 - Appendix in table 8-1 where 3 different cases and corresponding parameters are shown. The selection of optimal choke size is as following: first, if there are no significant changes in water rate for the three choke sizes, the one giving the biggest gas rate is chosen. Secondly, if water rate is high, around 2m<sup>3</sup>, then gas rate is compared for chokes and if there is no big difference, then middle choke size is selected. Finally, if water rate is bigger than 2,5m<sup>3</sup>, the smallest choke size – 4mm is chosen. After filtering the data, the optimal choke size and corresponding parameters are used for the neural network model.

There are several things that need to be considered in simulations and later optimal choke size selection. As the well X produces gas, liquid loading problem may occur. Liquid loading happens when gas velocity is not high enough to lift the liquid. In case of well X, water production is increasing, and this could be potential problem. However, in simulated

cases in PIPESIM, critical liquid loading values were compared to actual and the results showed it should not be a problem at the moment.

Another parameter that should be investigated is critical pressure drop ( $\Delta p$ ) at the choke. PIPESIM gives critical values that should not be exceeded, and values of the system installed. After comparison, it can be concluded which cases can be considered further for neural network model. However, in all cases,  $\Delta p$  of the system was below critical meaning all cases can be considered.

## 6. NEURAL NETWORK MODEL FOR WELL X

Final step of the thesis is building neural network. The idea is to see if neural network can predict optimal choke size as the data will come from sensors in real-time. It is assumed that sensors will send real-time data about bottomhole flowing pressure, gas rate and water rate and therefore, those were generated in PIPESIM for different cases and will be input data for the model. General workflow is described, and the results of the network are given. The neural network is made in Matlab software in package *DeepLearning Toolbox*.

When building a machine learning model, it is important to decide which type of learning process will be applied. As it can be seen in figure 6-1 there are two types available in Matlab. Based on the problem that is analysed and desired solutions, for the well X, supervised learning is chosen. Furthermore, classification is selected and finally neural network as a machine learning model.

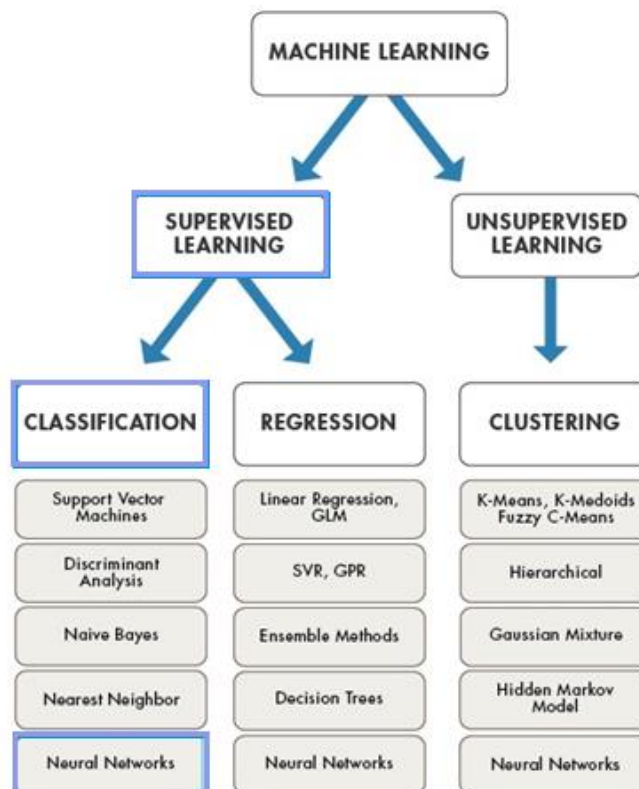

Figure 6-1. Different types of learning and models in machine learning according to Matlab

## 6.1. Workflow for the neural network model

The workflow for building the neural network consists of several steps:

1. Data acquisition and pre-processing,
2. Creating a neural network model
3. Network training and initialization of the weights and biases
4. Network validation

First step was described in chapter 5.2.2.2. Data was prepared in PIPESIM and Excel.

Second step is creating the model. Matlab function *nnstart* is used. This function opens a Network/Data Manager window - Neural Network Start window (figure 6-2) in which it is possible to select which type of network will be used. It offers four different networks: neural network fitting, pattern recognition, clustering and time series.

For the well X, it is decided to use Pattern Recognition app (function *nprtool*) to create the network. This function solves a classification problem by creating two-layer feed forward network. This neural network classifies input into target categories which are in this case choke sizes: 4, 6 or 8 mm.

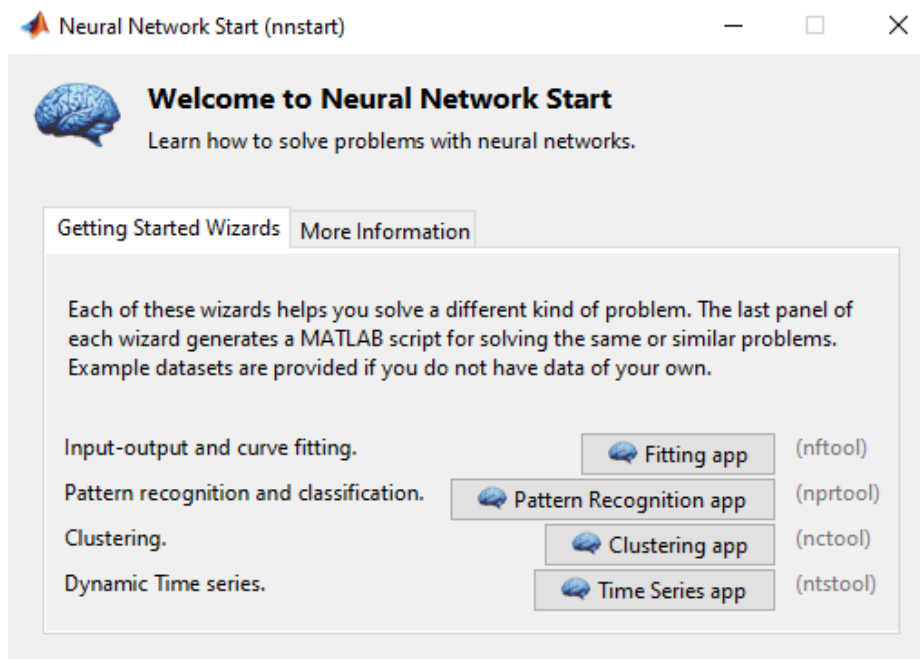

Figure 6-2. Network/Data Manager window for creating neural network (Matlab)

Neural network consists of input, hidden layers and output. Input and output are defined by importing excel sheet or writing the data directly in Matlab. One hidden layer is selected as this is enough for solving majority of problems according to literature. The number of neurons in the hidden layer can be defined according to several rules. According to Panchal and Panchal (2014.), there are several methods for selecting the hidden neuron number. They describe try and error method, rule of thumb method, simple method, two phase method, sequential orthogonal approach. However, to simplify, the selected number of hidden neurons is 10, as it is by default in Matlab.

Third step is training. When building the neural network model, one of the issues is which training function to choose. Training function selection depends on several factors such as complexity of the problem, is the model used for pattern recognition or regression, the number of data points, the error goal, the number of biases and weights. The training function used in this model is *Scaled Conjugate Gradient* (in Matlab *trainscg*). This training function is selected by default when choosing pattern recognition app. Data set is divide to 70% for training, 15% for validation and 15% for testing.

Final step is validation of the model. There are several parameters showing the performance and results of the network. In classification problem, percent misclassification error and cross-entropy are used. In addition, performance of the network can be evaluated from plots: matrix confusion plot, receiver operating characteristics (ROC) plot, performance plot, training state plot and error histogram.

### 5.2.2. Neural network for well X

The architecture of the created network is shown in figure 6-3. It is a two-layer network. It has hidden neuron where sigmoid function is applied and output neurons where softmax function is applied for calculations. The number of selected hidden neurons is 10, while size of input and output is 3.

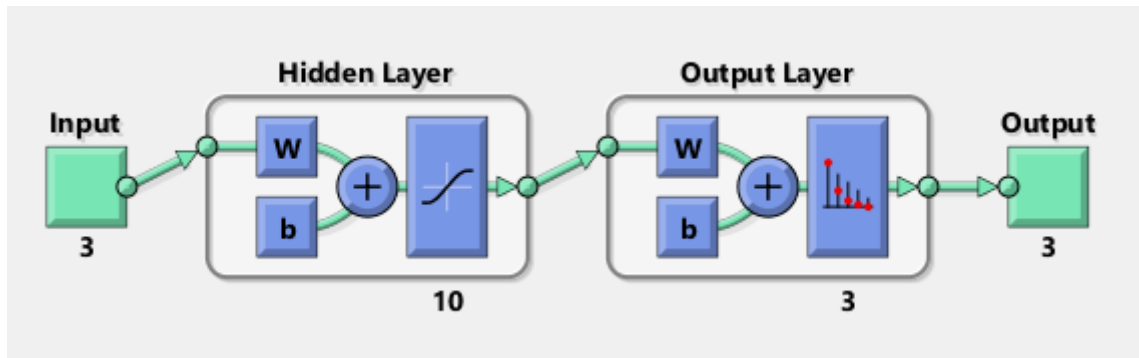

Figure 6-3. The architecture of the neural network for well X

In table 6-1 an example of the data used for creating network is shown. Input consists of 3 parameters: water rate, gas rate and bottomhole pressure. Optimal size for the given input is selected in the column target. As the network is supposed to solve classification problem, the target has to be in the form of vector. Therefore, targets are labelled as it is shown in the column Target (vector). The data set consists of 521 observations, which are divided in training set-365, validation set-78 and testing set-78.

Table 6-1. Example of the input and target subset data

INPUT			TARGET	TARGET (vector)		
Water rate (m3/day)	Gas rate (mmm3/day)	Bottomhole pressure (bar)	ICV size (mm)	8mm	6mm	4mm
0.50869	0.02543	57.436	8	1	0	0
0.47409	0.02370	68.287	6	0	1	0
0.52356	0.02618	71.631	6	0	1	0
0.57328	0.02866	75.140	6	0	1	0
0.62304	0.03115	78.806	6	0	1	0
0.66330	0.03316	81.810	6	0	1	0
0.52321	0.01308	77.977	4	0	0	1
1.12437	0.02811	60.591	8	1	0	0
1.26136	0.03153	62.649	8	1	0	0
1.40002	0.03500	64.955	8	1	0	0
1.22426	0.03061	79.581	6	0	1	0
1.30444	0.03261	82.569	6	0	1	0
1.45525	0.02426	59.702	8	1	0	0
1.65555	0.02759	61.542	8	1	0	0
1.86108	0.03102	63.567	8	1	0	0

After selecting input and target and importing it in Matlab, the next step is training the network. Training is performed until the validation set reaches the lowest possible values of the misclassification error and the cross-entropy value (figure 6-4). Cross-entropy (CE) is a number that gives the error in the model. The lower values are better while zero means no error. Percent error (%E) is the number that says how many percent of the sample is misclassified. 100 means maximum misclassification while 0 means no misclassification. It is important to point out that the network can be overtrained, meaning the network will start memorizing from training set instead of learning. Therefore, it is a challenge to train network long enough to make valid predictions but not too long, so the data is overfitted. Some of the advices when training the network are to stop when the validation set error is decreasing and then suddenly increase.

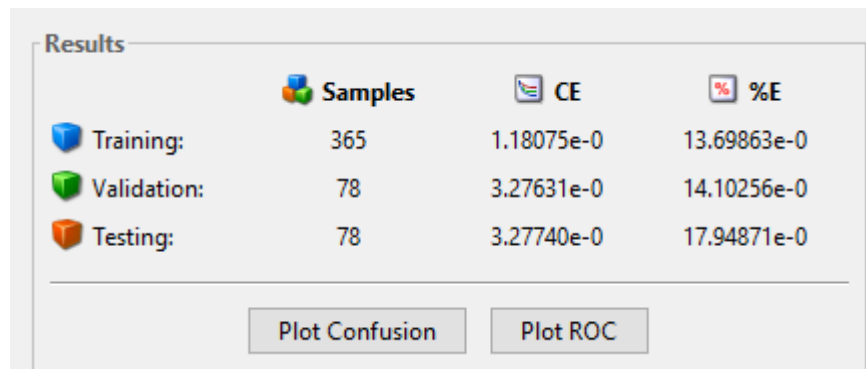

Figure 6-4. Cross-entropy and percentage of misclassification for training, validation and testing set

To validate and visualize results, matrix confusion plot, receiver operating characteristics (ROC), performance plot, training state plot and error histogram are used. Matrix confusion (figure 6-5) shows the percent of correct responses (in green squares) and percent of incorrect responses (in red squares). It basically gives information how good is the classifier. In the figure 6-5 a) the matrix shows the classification accuracy for the training data. The training data has 365 observations. The upper number in the squares shows the number of the observations classified in the particular class, while the lower number gives the percentage of the classified observations in that class. There are three classes, 1, 2 and 3 which represent the ICV sizes - 8, 6 and 4 mm. On the x line – Target Class, data represent the desired outcome of the model, while on the y-line – Output Class, data represent the actual output of the model. In the white squares, summation for each class is shown and in



the grey square overall classification accuracy. Figure b) shows the classification accuracy for the validation set which is 78 observations. The validation set is necessary to check if the model works properly and see if there is room for optimization of the model. In the validation of the model, training is not performed. The training of the model is only performed on the training set. Finally, a data set is selected for the testing of the model to see how the model will work on the future data coming in the network (figure c). In the figure d) summation of all confusion matrixes is shown and it represents overall classification accuracy. The neural network showed classification accuracy for the training 86,3%, for the validation 85,9% and for the testing 86,4%. That makes overall 85,6% classification accuracy of the model.



Figure 6-5. Confusion matrix

The ROC plots the true positive rate-sensitivity and false positive rate-specificity. In perfect neural network, plot would show points in the upper left corner and 100% sensitivity and 100% specificity. As it can be seen in figure 6-6, trend of the curves for each class fall towards left upper corner which indicates that the model is good. Figure a) represents the training of the model, b) shows the validation, c) how the model will work on new data – testing, and d) summation of all receiver operating characteristics.

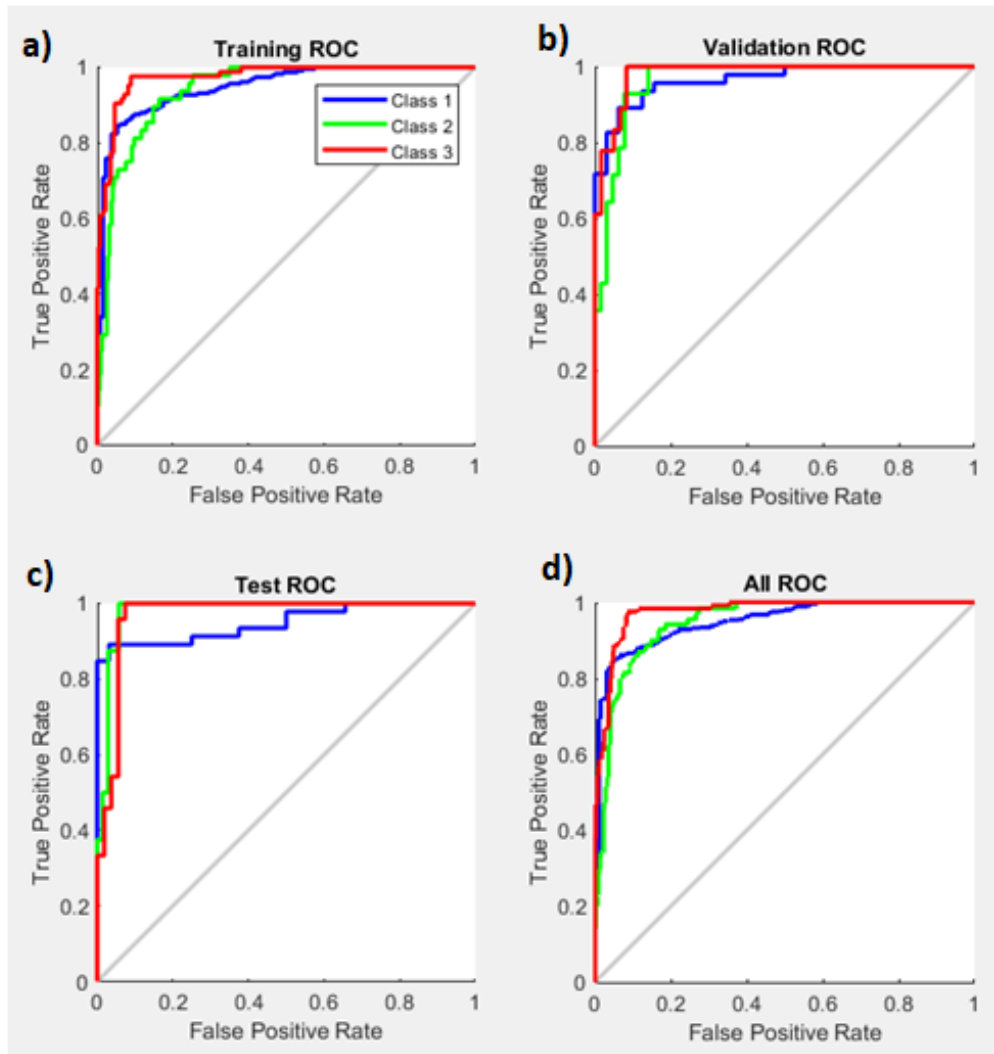

Figure 6-6. Receiver operating characteristic plot

The performance plot and training state plot give training statistics. The performance plot (figure 6-7) shows how the error reduces after certain number of epochs in the training. In the default, training stops after 6 increases in validation error. The best performance is taken from the epoch where is the lowest validation error. This graph can also show if the network is overfitting the training data. When it happens, the training curve increases significantly before the validation curve increases. In this model, curve follow the usual trend and there is no indication that overtraining happened. The training state plot (figure 6-8) shows the backpropagation gradient which shows when the local minimum of the function is reached. In addition, validation fails show when validation mean squared error increased which can also indicate if the model is overtrained or not.

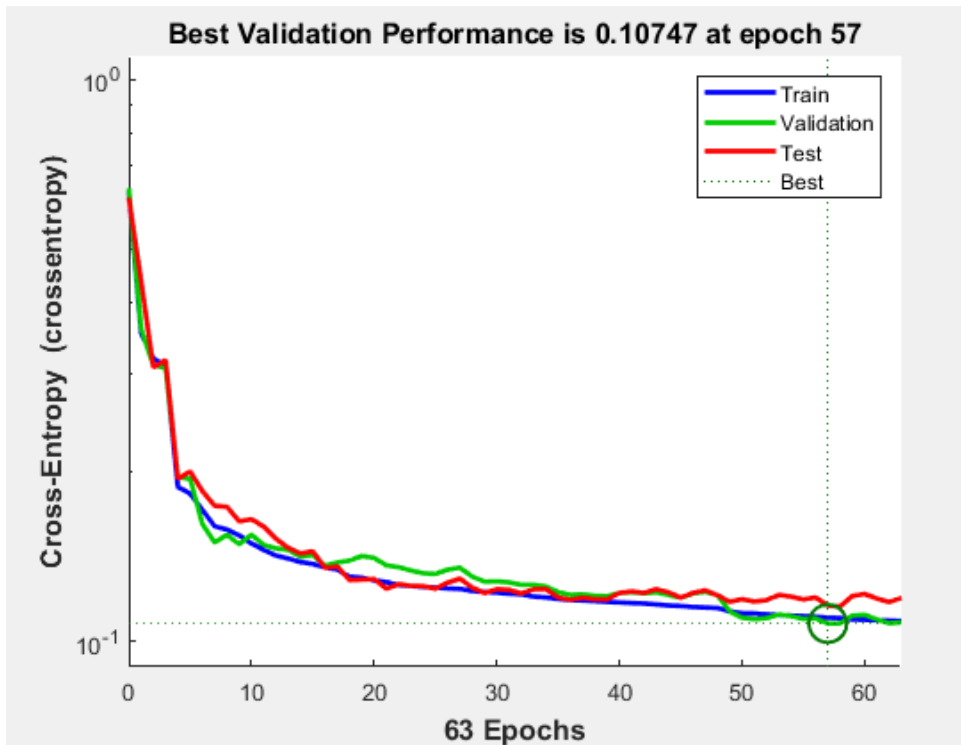

Figure 6-7. Training, validation and test performance plot

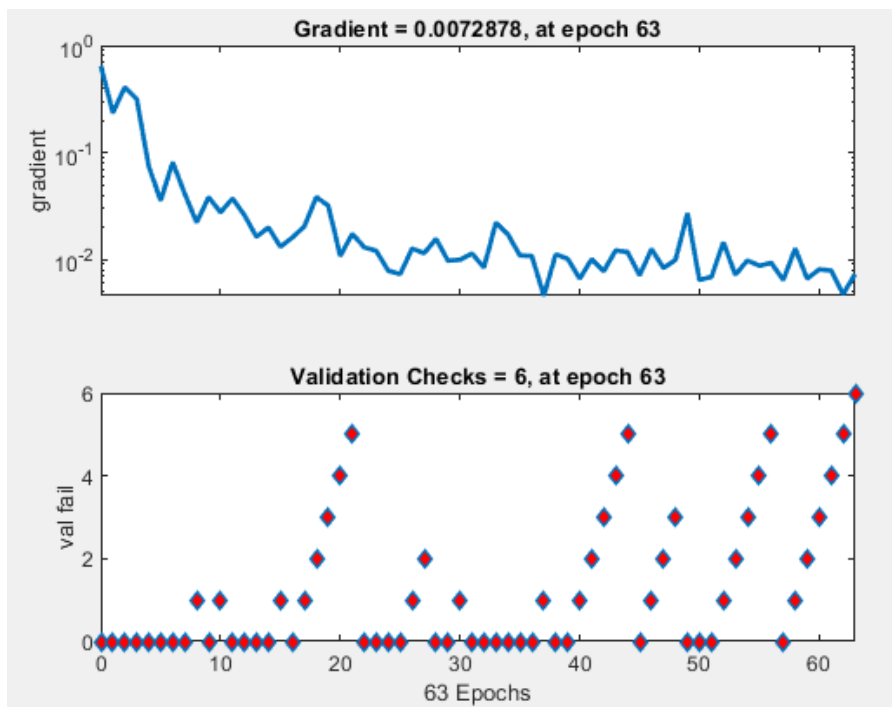

Figure 6-8. Training state plot

Error histogram is used as additional verification of the network and it shows error distribution for the number of observations. As it can be seen in figure 6-9, errors are normally distributed.

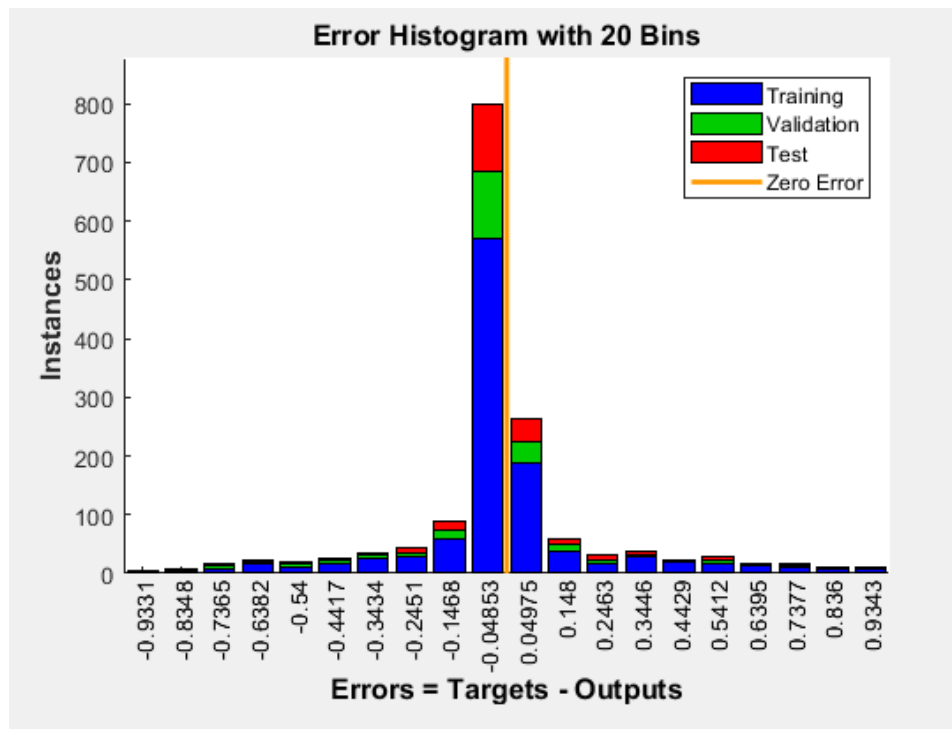

Figure 6-9. Error histogram

## 6.2. Discussion of the results

It is hard to strictly define when the neural network is good and will provide satisfying results after application. It depends on the problem and its complexity. According to <http://www.dataminingblog.com/what-is-a-good-classification-accuracy-in-data-mining/> in some cases the classification accuracy is more than 90% (face recognition), in other 55-60% (finances). In both cases this is a satisfying result. However, generally 80% of accuracy is considered to be good neural network model.

In the neural network created for the well X the classification accuracy of 85,6% presents good results. However, if we consider its application, the input data for this neural network will be coming in real-time from the sensors, which means this network will have much bigger set of data. That will constantly update network, and it can learn and train from new samples. Therefore, the classification accuracy can be even better. Another thing why it would be better if there was more input data, is that class 2 which is 6 mm choke has very small difference with 8mm choke in application. The results in confusion matrix show the poorest classification accuracy for the class 2. Based on the results, this model has problem

to classify input data to class 2, and it often happens that it misclassifies it into class 1 – 8 mm choke. Therefore, more data is needed to upgrade the neural network model.

In addition, fully closed or fully opened choke in this neural network model is not considered as it demands additional neural network because parameters to build it would not be the same. For example, for fully closed choke, there would not be bottomhole flowing pressure but static pressure, and gas rate and water rate would be zero. This requires more data analysis and analytical thinking in order to create the network. It can be recommended as the next step to develop a complete automatization of the ICVs.

After all benefits of the neural networks are mentioned it is also important to emphasize the setbacks. The disadvantage of neural network is when it does not perform well, or in other words it does not give expected results, it is very hard to figure out the reason why. That is one of the reasons why neural network is often called “black box”. Therefore, if there is an explanation needed what and how something happened in the network, the neural networks may not be the best machine learning tool.

## 7. CONCLUSION

Nowadays, intelligent completion found many applications and has many advantages. Some of those are reduced well interventions, better reservoir management, faster response to unexpected changes and better gas/water injection control. However, there are still some setbacks such as significantly higher costs, plugging and damage of ICVs and the inability to handle abundance of data coming from sensors. It is necessary to make good planning and consider all possible issues before implementing such expensive equipment. The thesis considered possible implementation of the intelligent equipment in well X instead of the current conventional completion. Several scenarios were simulated in PIPESIM to see how ICVs will regulate gas and water production. The results of simulations were used to build neural network. The results showed that it could be feasible to manage ICVs through neural network with more than 85% model accuracy. However, there is a need for much more data to be able to create high quality network. If it was a real case, the data will be coming in the real-time from the sensors and there will be enough data to create and test network for this application. Furthermore, the network will be constantly updated and learn from new data, as it is coming to surface monitoring system. The good model also includes trial and error process in defining compatible hidden neuron number and the training duration as there is no universal rule to define those parameters.

In the end, although neural network showed to be very convenient in solving problems, it is still often called “black box”. The name comes from the inability to completely understand what happens in the hidden layers. Therefore, the output cannot be explained by simple mathematical and statistical calculations. It is impossible to completely rely on the machine learning without critical and analytical thinking of the engineers.

## 8. REFERENCES

1. ABDULLAYEV, A., KEDIA; R., URAKOV, A., TEMIZEL, C. 2017. Optimization of recovery using intelligent completions in intelligent fields. SPE-188993. SPE Annual Caspian Technical Conference and Exhibition, Baku, Azerbaijan, 1-3 November 2017.
2. AL-KHELAIWI, F.T., DAVIES, D.R. 2007. Inflow control devices: Application and value quantification of a developing technology. SPE-108700. International oil conference and exhibition, Veracruz, Mexico, 27-30 June 2007.
3. BECKENKAMP, F.G., 2002. A component architecture for artificial neural network systems. PhD dissertation. University of Constance, Computer and Information Science.
4. BELLARBY, J. 2009. Well completion design. Elsevier. Vol. 56. Oxford, UK.
5. BIRCHENKO, V.M. 2010. Analytical modelling of wells with inflow control devices. Doctoral dissertation. Institute of Petroleum Engineering, Heriot-Watt University, July 2010.
6. CARVAJAL, G., MAUCEC, M., CULLICK, S. 2018. Intelligent digital oil and gas fields: Concepts, collaboration and right-time decisions. Gulf Professional Publishing, Elsevier, Oxford, UK.
7. CORREA, N.A., BARCELOS, T.F.P., MIURA, K., MENDES, J.R.P. 2017. Intelligent completion or well intervention robot. SPE-188880. Abu Dhabi International Petroleum Exhibition & Conference, Abu Dhabi, UAE, 13-16 November 2017.
8. ELLIS, T., ERKAL, A., GOH, G., JOKELA, T., KVERNSTUEN, S., LEUNG, E., MOEN, T., PORTURAS, F., SKILLINGSTAD, T., VORKINN, P.B., RAFFN, A.G. 2009. Inflow control devices – Raising profiles. Oilfield review winter 2009/2010 21 no.4.
9. FRUHWIRTH, R. 2018/2019. Lecture notes from course Production Data Analysis and Modeling. Montanuniversität Leoben, Department Petroleum Engineering, winter semester 2018/2019.
10. GAO, C., RAJESWARAN, T., CURTIN, U., NAKAGAWA, E. 2007. A literature review on smart well technology. SPE-106011. SPE Production and Operations Symposium, Oklahoma City, Oklahoma, USA, 31 March – 3 April 2007.
11. GARCIA E., MATHEW, M. 2016. Delivering selective interval control: Electro-hydraulic intelligent completion enhances reservoir management for multilateral wells. SPE/IADC 178168. SPE/IADC Middle East Drilling Technology Conference and Exhibition, Abu Dhabi, UAE, 26-28 January 2016.



12. GARCIA, E., SALDANHA, S. 2016. Electrohydraulic ICV control system: A novel approach to multizonal control. OTC-26816. Offshore Technology Conference, Kuala Lumpur, Malaysia, 22-25 March 2016.
13. GLANDT, C.A. 2003. Reservoir aspects of smart wells. SPE-81107. SPE Latin American and Caribbean Petroleum Engineering Conference, Port-of-Spain, Trinidad, West Indies, 27-30 April 2003.
14. GOODFELLOW, I., BENGIO, Y., COURVILLE, A. 2016. Deep Learning. An MIT Press book. <http://www.deeplearningbook.org/>.
15. HODGES, S., OLIN, G., SIDES, W. 2000. Hydraulically actuated intelligent completions: Development and applications. OTC-11933. Offshore Technology Conference, Houston, Texas, USA, 1-4 May 2000.
16. HUSAIN, Z.B., AL-HAJRI, M.A. 2013. Quantifying the intelligent field added values. SPE 167439. SPE Middle East Intelligent Energy Conference and Exhibition, Dubai, UAE, 28-30 October 2013.
17. JOUBRAN, J. 2018. Intelligent Completion: Design and reliability of interval control valves in the past, present and future. OTC-28917. Offshore Technology Conference, Houston, Texas, USA, 30 April – 3 May 2018.
18. KRIESEL, D. 2007. A brief introduction to neural networks. Available at: <http://www.dkriesel.com>.
19. LAROSE, D.T. 2005. Discovering knowledge in data: An introduction to data mining. A Jon Wiley & Sons, Inc., Publication, New Jersey, USA.
20. LI, A., ALOBEDLI, A., SELVAM, B., AZOUG, Y., OBETA, C., Nguyen, M., AL-SHEHHI, B.H. 2017. A new ICD/ICV well completion design optimizer and well management logic for full field reservoir simulation with multiple ICD/ICV wells. SPE-188642. International Petroleum Exhibition and Conference, Abu Dhabi, UAE, 13-16 November 2017.
21. LI, Z., FERNANDES, P., ZHU, D. 2011. Understanding the roles of inflow control devices in optimizing horizontal well performance. SPE-124677-PA.
22. MOKHTARI, K., WALTRICH, P.J. 2016. Performance evaluation of multiphase flow models applied to virtual flow metering. 11<sup>th</sup> International Conference on Engineering Sciences, September 2016.
23. PANCHAL, F., S., PANCHAL, M. 2014. Review on methods of selecting number of hidden nodes in artificial neural network. International Journal of Computer Science and Mobile Computing, Vol.3, Issue 11, pages 455-464, November 2014.

24. RANJITH, R., SUHAG, A., BALAJI, K., PUTRA, D., DHANNOON, D., SARACOGLU, O., HENDROYONO, A., TEMIZEL, C., AMINZADEH, F. 2017. Production optimization through utilization of smart wells in intelligent fields. SPE-185709. SPE Western Regional Meeting, Bakersfield, California, USA, 23 April 2017.
25. ROBINSON, M. 2003. Intelligent well completions. SPE-80993. Journal of petroleum technology, August 2003.
26. SHAW, J. 2011. Comparison of downhole control system technologies for intelligent completions. CSUG/SPE 147547. Canadian Unconventional Resources Conference, Calgary, Alberta, Canada, 15-17 November 2011.
27. TEMIZEL, C., AKTAS, S., KIRMACI, H., SUSUZ, O., ZHU, Y., BALAJI, K., RANJITH, R., TAHIR, S., AMINZADEH, F., YEGIN, C. 2016. Turning data into knowledge: Data surveillance and optimization in mature fields. SPE-181881. SPE Annual Technical Conference and Exhibition, Dubai, UAE, 26-28 September 2016.
28. VAN DEN BERG, F. 2007. Smart Fields-Optimizing existing fields. SPE-108206. SPE Digital Energy Conference and Exhibition, Huston, Texas, USA, 11-12 April, 2007.
29. VAN DEN BERG, F., PERRONS, R.K., MOORE, I., SCHUT, G. 2010. Business Value from intelligent fields. SPE-128245. SPE Intelligent Energy Conference and Exhibition, Utrecht, Netherlands, 23.25 March 2010.
30. VAN DER STEEN, E. 2006. An evolution from smart wells to smart fields. SPE-100710. SPE Intelligent Energy Conference and Exhibition, Amsterdam, Netherlands, 11-13 April 2006.
31. WIRTH, R., HIPPEL, J. 2000. CRISP-DM: Towards a Standard Process Model for Data Mining. <http://citeseerx.ist.psu.edu/viewdoc/summary?doi=10.1.1.198.5133>
32. ZANGL, G., HANNERER, J. 2003. Data Mining: Applications in the petroleum industry. Round Oak Publishing, United States of America.

#### WEB SOURCES:

33. DataMining.Blog.com, April 2010. What is a good classification accuracy in data mining, URL: <http://www.dataminingblog.com/what-is-a-good-classification-accuracy-in-data-mining/> (29 August 2019)
34. Haliburton, April 2017. Autonomous inflow control device, URL:

- <https://www.halliburton.com/en-US/ps/completions/sand-control/screens/inflow-control/equiflow-autonomous-inflow-control-device.html?contentType=Data%20Sheets&index=0&comp=C> (7 August 2019)
35. Locke Data, CRISP-DM model, January, 2017. URL: <https://itsalocke.com/blog/crisp-dm-and-why-you-should-know-about-it/> (25 August 2019)
36. Machine learning mastery, December 2018. A gentle introduction to early stopping to avoid overtraining neural networks, URL: <https://machinelearningmastery.com/early-stopping-to-avoid-overtraining-neural-network-models/> (24 August 2019)
37. Schlumberger, 2019. Different ICV types with various choking positions, URL: <https://www.slb.com/completions/well-completions/intelligent-completions/downhole-interval-control-valves> (7 August 2019)
38. Towards data science, August 2017. The mostly complete chart of neural networks, explained, URL: <https://towardsdatascience.com/the-mostly-complete-chart-of-neural-networks-explained-3fb6f2367464> (1 July 2019)

## 9. APPENDIX

Table 8-1. Example of the data generated in PIPESIM after system analysis and how optimal choke size is selected for certain case

	Outlet pressure (bar)	WGR (sm <sup>3</sup> /mmsm <sup>3</sup> )	Choke size (mm)	Reservoir pressure (bar)	Stock tank liquid rate (m <sup>3</sup> /day)	Stock tank gas rate (mmm <sup>3</sup> /day)	BHFP (bar)	Liquid Loading gas rate maximum (mmm <sup>3</sup> )	Choke Critical Pressure ratio	Choke Delta P	Choke Critical Delta P	Status
1	40	20	4	95.003	0.26864	0.01343	77.47	0.03650	0.53	27.26	36.40	Not optimal
	40	20	6	95.003	0.42498	0.02125	65.12	0.03642	0.53	15.01	30.60	Not optimal
	40	20	8	95.003	0.50869	0.02543	57.44	0.03639	0.53	7.28	26.99	Optimal
2	40	80.002	4	110	1.30846	0.01636	91.75	0.03646	0.53	37.42	43.11	Not optimal
	40	80.002	6	110	2.18043	0.02725	77.22	0.03637	0.53	23.03	36.28	Optimal
	40	80.002	8	110	2.72187	0.03402	66.63	0.03631	0.53	12.38	31.31	Not optimal
3	40	300	4	105	3.81366	0.01271	90.35	0.03692	0.53	27.14	42.45	Optimal
	40	300	6	105	6.33152	0.02111	79.20	0.03703	0.53	16.00	37.21	Not optimal
	40	300	8	105	7.85987	0.02620	71.60	0.03709	0.53	8.24	33.64	Not optimal

## STATEMENT

I declare that I wrote my master thesis based on the knowledge gained at Faculty of Mining, Geology and Petroleum Engineering supported by mentioned literature.

---

Monika Miličević